

# STERIS

## INSTALLATION, OPERATION

**Electric Steam Boiler  
Type CH02 – CH14**

**Standard Trim – 100 PSI  
0-90 PSI Operation Pressure**

Model Number _____	Power Circuit Voltage _____
Boiler Serial Number _____	Control Circuit Voltage _____
National Board Number _____	Amp _____ Ph _____ Cy _____
Customer to complete for future reference	

### SPECIFICATIONS

Three Phase Voltage										
Catalog Number	kW	B.H.P. Rating	Output in lbs./hr at 80 psi with 140° F feedwater	Quantity and rating of contactors			Quantity and rating of heater fuses			No. and kW of heating elements
				208	240	480	208	240	480	
CH02	10	1	31.6	1-40	1-40	1-40	--	--	--	1-10 kW
CH03	15	1.5	47.4	1-50	1-40	1-40	3-60	--	--	1-15 kW
CH04	20	2	63.2	1-65	1-50	1-40	3-70	3-60	--	1-20 kW
CH05	30	3	94.9	2-50	2-50	1-40	6-60	4-45	--	1-30 kW
CH06	40	4.1	126.5	2-65	2-50	1-50	6-70	6-60	3-60	2-20 kW
CH07	60	6.1	189.7	4-50	4-50	2-50	12-60	12-50	6-50	2-30 kW
CH08	75	7.7	237.2	4-65	4-50	2-50	12-70	12-60	6-60	2-37.5 kW
CH10	102	10.4	322.5	6-50	6-50	3-50	18-60	18-60	9-60	3-34 kW
CH12	120	12.2	379.5	6-65	6-50	3-50	18-70	18-60	9-60	3-40 kW
CH13	150	15.3	474.3	8-65	8-50	4-50	24-70	24-60	12-60	4-37.5 kW
CH14	180	18.4	569.2	8-65	8-65	4-65	24-80	24-70	12-70	4-45 kW

**MODELS CH 02 THROUGH CH 04**

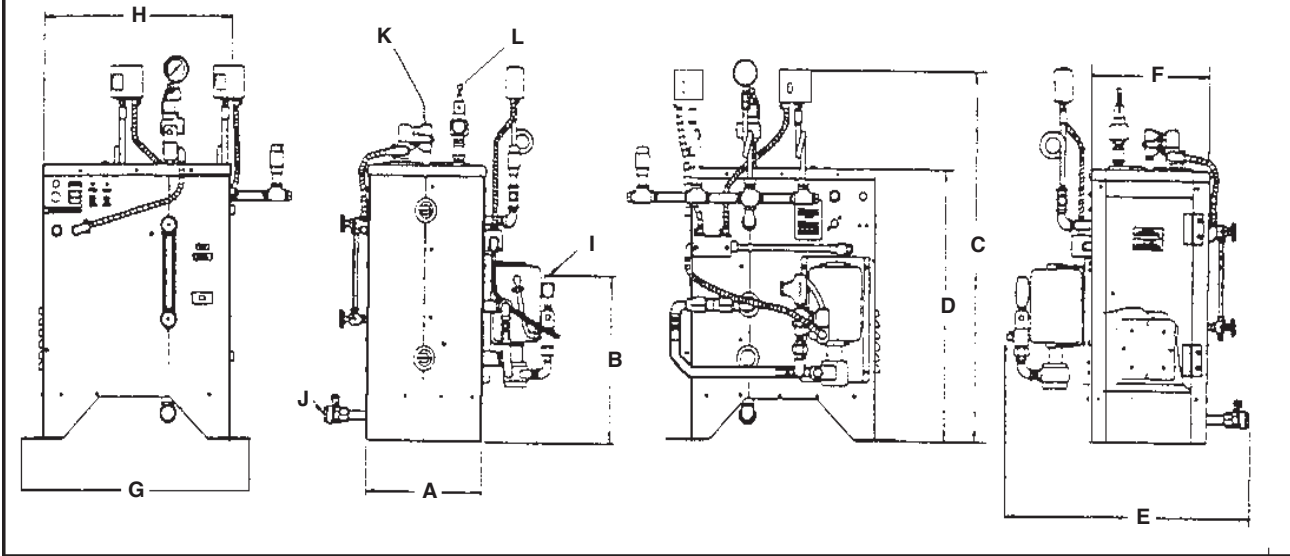

**MODELS CH 05 THROUGH CH 14**

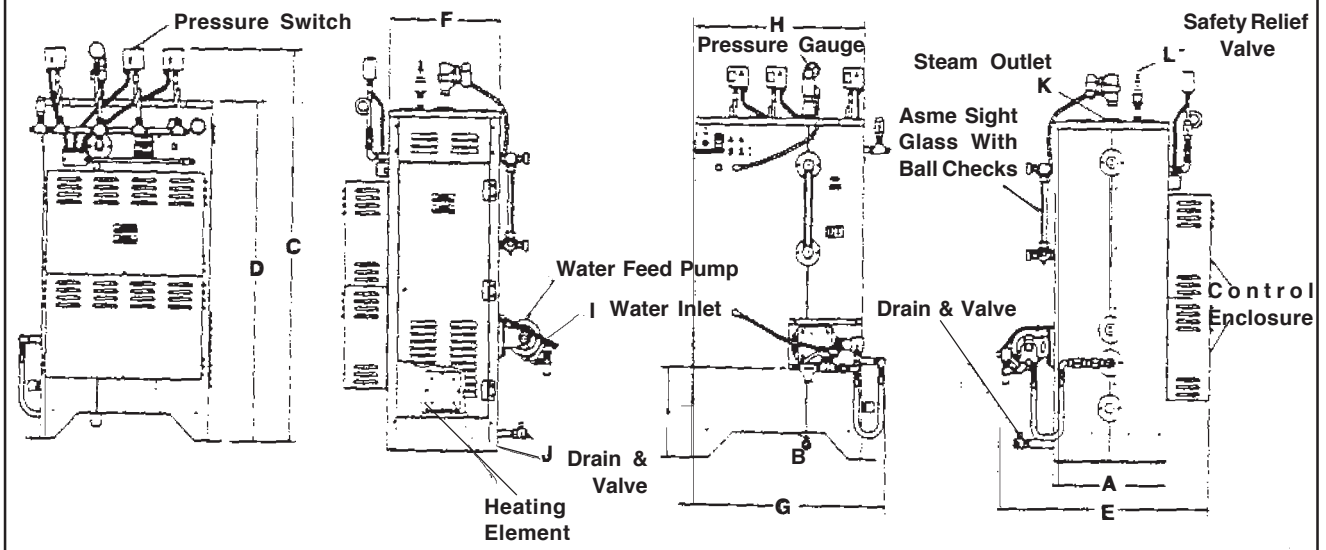

## DIMENSIONS (IN INCHES)

Catalog												
Number	A	B	C	D	E	F	G	H	I	J	K	L
CH02	12 -3/4	19 -1/2	35	27 -1/4	29 -11/16	12 -3/4	24 -3/8	20	1/2	1/2	1/2	1/2
CH03	12 -3/4	19 -1/2	35	27 -1/4	29 -11/16	12 -3/4	24 -3/8	20	1/2	1/2	1/2	1/2
CH04	12 -3/4	19 -1/2	35	27 -1/4	29 -11/16	12 -3/4	24 -3/8	20	1/2	1/2	1/2	1/2
CH05	15	4	43 -7/8	35 -7/8	30 -3/8	15	28 -5/8	24-3/16	1/2	1	3/4	1/2
CH06	15	4	43 -7/8	35 -7/8	30 -3/8	15	28 -5/8	24-3/16	1/2	1	3/4	1/2
CH07	15	4	43 -7/8	35 -7/8	30 -3/8	15	28 -5/8	24-3/16	1/2	1	3/4	1/2
CH08	15	4	43 -7/8	35 -7/8	30 -3/8	15	28 -5/8	24-3/16	1/2	1	3/4	1/2
CH10	18	17 -5/8	60	50 -7/8	34 -1/4	18	33 -1/8	27 -3/16	1/2	1	1	3/4
CH12	18	17 -5/8	60	50 -7/8	34 -1/4	18	33 -1/8	27 -3/16	1/2	1	1	3/4
CH13	18	17 -5/8	60	50 -7/8	34 -1/4	18	33 -1/8	27 -3/16	1/2	1	1	3/4
CH14	18	17 -5/8	60	50 -7/8	34 -1/4	18	33 -1/8	27 -3/16	1/2	1	1	3/4

## INSTALLATION

**WARNING - Hazard of electrical shock and severe burn: Injury or death may occur if this equipment is not properly installed and operated. The boiler must be grounded using the grounding means provided and be wired in accordance with the National Electrical Code by a qualified person after reviewing the installation and operating instructions for your electric steam boiler.**

NOTE: When installing the boiler, allow sufficient room (18 inches minimum) to allow removal of the heating element if and when necessary.

1. The boiler should be mounted on a solid, level foundation, near floor drain. Provisions should be made to prevent damage in the event the boiler leaks water or discharges steam.
2. A minimum distance of 18 inches between the boiler and any combustible material must be maintained.
3. Complete all piping to the boiler. Connect the water line to the fitting on the pump and the motor assembly.
4. When using any type of water feed other than the pump feed provided with the boiler, the incoming water supply must be 10 psig greater than the operating pressure of the boiler. This is required to maintain a proper water level in the boiler. Failure to maintain the proper water level may cause heater failure. Keep the feed water line valve open at all times except during blowdown.
5. Connect the steam line, using a globe valve, to the boiler steam outlet. The valve should be placed as close as possible to the boiler outlet and sized per the label on the boiler.
6. To maximize the efficiency, all steam piping from the outlet should be insulated.
7. Drain and relief valve piping should be installed in accordance with state and local codes.
8. Only a qualified person, aware of local and national electrical and plumbing codes, should install this equipment.

## WATER SPECIFICATION

STERIS recommends supplying the boiler with hot water at 140° F or 60°C, (Maximum 150°F or 65°C) to minimize the heat-up time and conserve electricity. Colder water can be used but will result in a longer heat-up time and reduced steam output.

Feed water varies considerably with site location. For proper boiler operation and reasonable element life, STERIS recommends the feed water quality be controlled within the following parameters.

The recommended total hardness should be 0-17 mg/l, specific resistance not to exceed 26,000 Ω/cm with pH maintained between 6.8 and 7.5. Total dissolved solids should not exceed 250 PPM and alkalinity (bicarbonate only) should not exceed 180 PPM as calcium carbonate.

If the available feed water source does not meet the above requirements, contact a water treatment company for recommendations for water supply modifications. Failure to supply water within the above specifications may decrease the boiler life and may cause failures not covered by equipment warranty.

### ENGINEERING DATA

Rating (kW)	10	15	20	30	40	60	75	102	120	150	180
<b>Boiler Horsepower</b>	1	1.5	2	3	4.1	6.1	7.7	10.4	12	15.3	18.4
<b>Steam output in lbs./hr at 80 psig with 140° F feedwater</b>	31.6	47.4	63.2	94.9	126.5	189.7	237.2	322.5	379.5	474.3	569.2
<b>Gross output in BTU/hr</b>	34,120	51,180	68,240	102,360	136,480	204,720	255,900	348,024	409,440	511,800	614,160
<b>Approx. operating weight in lbs. (kg)</b>	230 (104)	230 (104)	230 (104)	400 (181)	410 (186)	420 (190)	430 (195)	940 (425)	945 (428)	950 (430)	960 (434)
<b>Electrical consumption in Amps</b>											
<b>208 Volt, 3 Phase</b>	28	42	56	83	111	167	210	283	333	416	500
<b>240 Volt, 3 Phase</b>	24	36	48	72	96	144	180	245	289	361	433
<b>480 Volt, 3 Phase</b>	12	18	24	36	48	72	90	123	144	180	217
<b>Water consumption in gph (lph) at</b>											
<b>Steam output of 80 psi with 140 F feedwater</b>	3.8 (14.4)	5.7 (21.6)	7.6 (28.8)	11.5 (43.5)	15.2 (57.5)	22.7 (85.9)	28.4 (107.5)	38.7 (146.5)	45.5 (172.2)	56.9 (215.4)	68.2 (258.1)
<b>Approx. heat loss in BTU/hr at 70°F ambient continuous operation</b>	850	850	850	1750	1750	2600	3500	4400	4800	4800	4800