

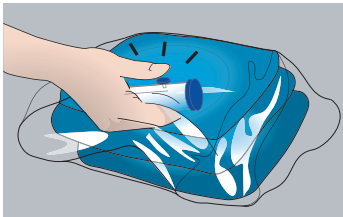

Andersen EOGas Sterilizers combine the proven reliability of ethylene oxide with a unique delivery system that uses less than 11cc of gas per cycle - almost 90% less gas than our closest competition. EOGas is the most delicate sterilization system on the market and will not damage delicate items such as electronics, fiber-optics, endoscopes, cameras, or laptop computers. Ideal for long lumens, heat sensitive materials, and plastics. Bag and cartridge size can be customized to your product. Fully validatable - for medical device manufacturing.



Unique sterilization system uses unit dose cartridges and plastic sterilization bags, *no external EO tanks.*



Batch processing for small production lots in the manufacture of medical devices.

EOGas - The Future of Ethylene Oxide Sterilization



AN310
(AN300 Base Cabinet
unavailable)

AN333

EOGas[®] series 3 plus *STERILIZER TECHNICAL SPECIFICATIONS*

AN310

Inner - 24.5" W (62.23 cm) x 22.25" D (56.52 cm) x 26.5" H (67.31 cm)
 Overall Outer - 36.25" W (92.08 cm) x 26.125" D (66.36 cm) x 42" H (106.68 cm)
 B: 36.25" with label printer mount

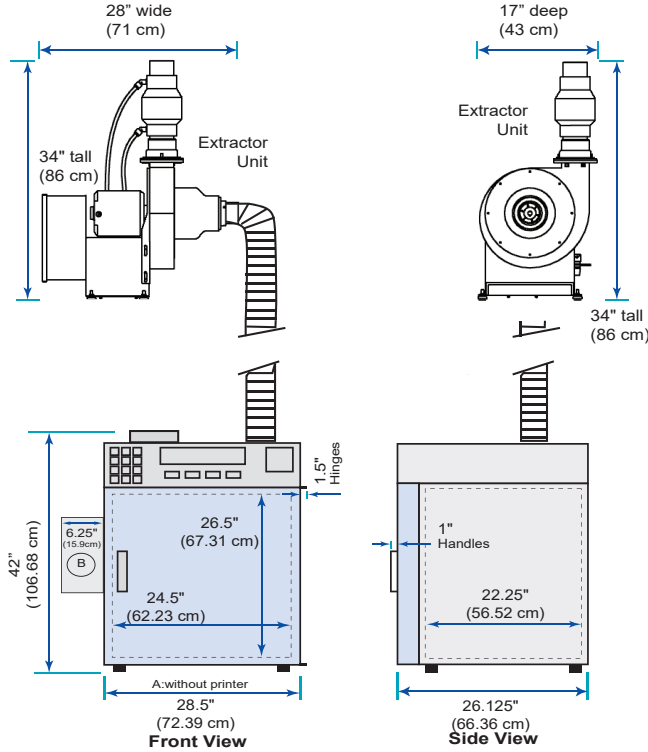

AN333

Inner - 31" W (78.74 cm) x 28" D (71.12 cm) x 65.5" H (166.37 cm)
 Overall Outer - 41.75" W (106.05 cm) x 31.5" D (80 cm) x 79"H (200.66 cm)
 B: 41.75" with label printer mount

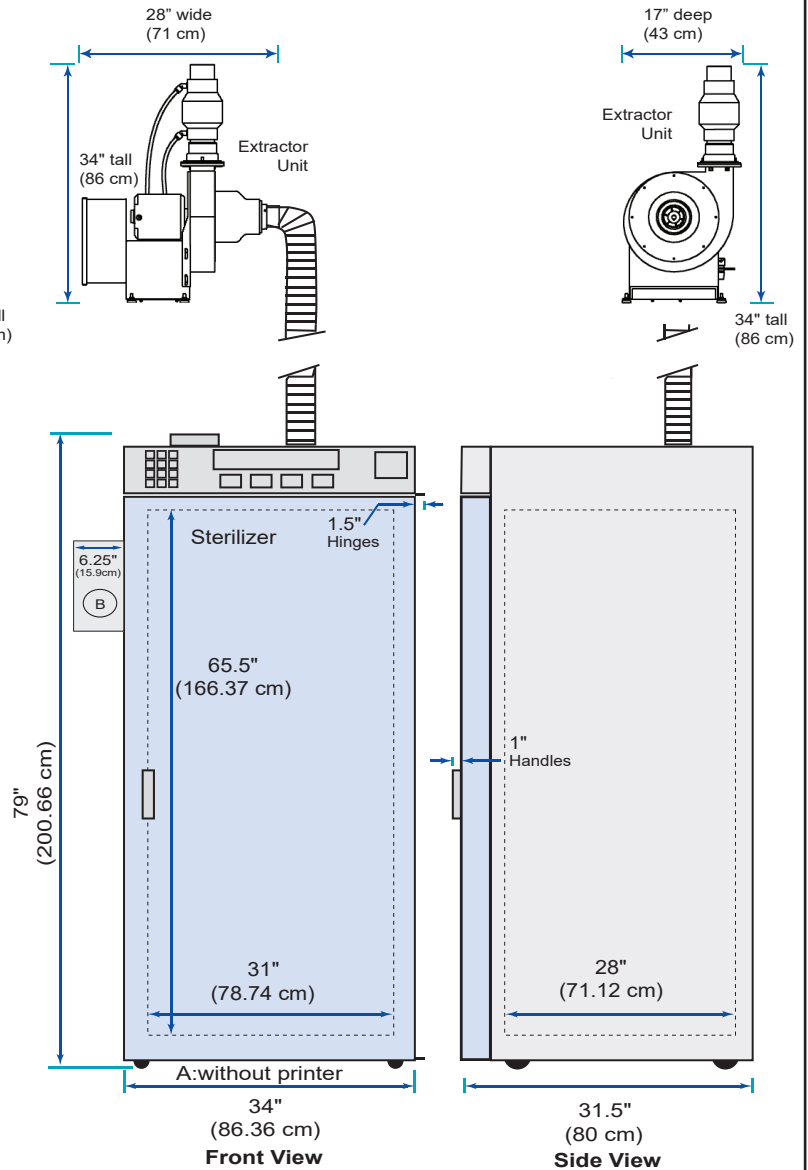

MADE WITH PRIDE



IN THE USA

| Model No. | Description | Capacity | Operational Weight | | Exhaust Requirements | Power Requirements |
|-----------|---|----------|--------------------|-----------------|--------------------------------------|-------------------------------|
| | | | Cabinet | Extractor | | |
| AN310 | Free-standing sterilizer cabinet and extractor unit | 10 cu ft | 285 lbs (130 kg) | 10 lbs (4.5 kg) | Dedicated 3" (7.6 cm) discharge vent | 220/240 V, 50/60 Hz, 5.4 Amps |
| AN333 | High-capacity free-standing sterilizer cabinet and extractor unit | 33 cu ft | 630 lbs (286 kg) | 10 lbs (4.5 kg) | Dedicated 3" (7.6 cm) discharge vent | 220/240 V, 50/60 Hz, 5.4 Amps |



39 Western Hwy.
 West Nyack, NY
 10994
 www.DuralineSystem.com
 877-561-0500