

Tuttnauer

Your Sterilization & Infection Control Partners

OPERATION & MAINTENANCE MANUAL

**Electronic Table -Top Autoclaves
models 1730, 2340, 2540, 3545, 3850, 3870E
2340, 2540, 3850, 3870 EA
2540EK, EKA**

Cat. No. MAN205-0112003EN Rev. L

☑ Heidolph Brinkmann, LLC, 1241 Jarvis Avenue, Elk Grove Village, IL 60007, ☎ 856-786-1448, Toll Free phone: 866-650-9604,
☐ Fax: 856-949-1167
☑ Brinkmann Instruments (Canada) Ltd. 4160 Sladeview Crescent #6, Mississauga, Ontario L5N 2L8, ☎ (905) 569-0664, Toll Free: (866) 260-6069,
☐ Fax: (905) 569-0665

1-224-265-9600

TABLE OF CONTENTS

PARAGRAPH	PAGE NO.
1. GENERAL.....	4
1.1 Incoming Inspection.....	4
1.2 Warranty.....	4
2. TECHNICAL DATA.....	5
2.1 Introduction.....	5
2.2 Stand – by heating mode.....	5
2.3 Environment Emission Information.....	5
2.4 Operating Conditions.....	6
2.5 Utilities.....	6
2.6 Construction.....	6
2.7 Symbol Description.....	6
2.8 Electrical Data.....	7
2.9 Specifications.....	8
2.10 Technical Specifications.....	9
2.11 Directives and Standards.....	10
2.12 Water quality.....	11
3. KEYBOARD (keys and display).....	16
3.1 Indicator Light Description.....	17
3.2 Description and Functions of the Control Panel Keyboard.....	18
3.3 Description of the Display Panel.....	20
3.4 Description of Displayed messages and Safety Measures.....	20
4. STERILIZATION PROGRAMS.....	23
4.1 PROGRAM 1. Unwrapped Instruments.....	23
4.2 PROGRAM 2. Wrapped Instruments and Porous Loads.....	24
4.3 PROGRAM 3: Liquids.....	25
4.4 PROGRAM 4: Accessory (Dry Only).....	25
5. PRINTER (Optional).....	26
5.1 Printer Operation.....	26
5.2 Printer Handling.....	28
6. INSTALLATION INSTRUCTIONS.....	29
6.1 Electrical.....	29
6.2 Automatic Water Filling.....	31
6.3 Lifting and carrying.....	32
6.4 Loading and unloading the Device.....	33
6.5 Filling the Water Reservoir.....	33
7. PREPARATION BEFORE STERILIZATION.....	34
8. OPERATING INSTRUCTIONS.....	37
9. MAINTENANCE INSTRUCTIONS.....	40

9.1	<i>Preventive and Scheduled Maintenance</i>	40
9.2	<i>Replacing the Air Filter (models EA)</i>	41
9.3	<i>Draining the Reservoir</i>	42
9.4	<i>Cleaning Air Jet</i>	43
9.5	<i>Replacing the Door Gasket</i>	44
9.6	<i>Checking the Safety Valve</i>	45
9.7	<i>Replacing the Fuse</i>	46
9.8	<i>Cleaning water outlet strainer</i>	47
9.9	<i>Cleaning Table Top Autoclaves with Chamber Brite™</i>	48
9.10	<i>Water Sensor Cleaning</i>	50
10	TROUBLESHOOTING FOR THE OPERATOR	51

TABLE OF CONTENT (Cont.)

DRAWINGS	PAGE NO.
<i>Front View, Model 1730</i>	<i>12</i>
<i>Front View Models 2340/2540</i>	<i>13</i>
<i>Front View Models 3545/3850/3870</i>	<i>14</i>
<i>Rear View</i>	<i>15</i>
<i>Front Panel Keyboard</i>	<i>16</i>

1. **GENERAL**



Read the Operating Instructions carefully, before beginning any operation on the autoclave!

1.1 **Incoming Inspection**

Upon receiving your Tuttnauer Autoclave carefully inspect the outside of the shipping carton for signs of damage. If any damage to the carton is found note the location with respect to the autoclave and check that area of the autoclave carefully once it is fully unpacked. Observe packing method and retain packing materials until the unit has been inspected. Mechanical inspection involves checking for signs of physical damage such as: scratched panel surfaces, broken knobs, etc.

If any damage is found contact your dealer as soon as possible so that they can file a claim with the shipping carrier and also notify Tuttnauer. All Tuttnauer products are carefully inspected prior to shipment and all reasonable precautions are taken in preparing them for shipment to assure safe arrival at their destination.

Note: Lifting and carrying should always be done by two people.

1.2 **Warranty**

For warranty information on this unit please contact your dealer or Brinkmann Instruments at one of the #'s listed below:

☐ Heidolph Brinkmann, LLC, 1241 Jarvis Avenue, Elk Grove Village, IL 60007,

☎ 856-786-1448, Toll Free phone: 866-650-9604, ☐ Fax: 856-949-1167

Brinkmann Instruments (Canada) Ltd. 4160 Sladeview Crescent #6, Mississauga, Ontario L5N 2L8, Ph: (905) 569-0664, Toll Free: (866) 260-6069, Fax: (905) 569-0665

2. **TECHNICAL DATA**

2.1 **Introduction**

This table-top autoclave is designed for the sterilization of wrapped and unwrapped instruments and related items found in dental, medical and veterinary clinics, first aid rooms, hospitals, laboratories etc.

This autoclave is an electrically - heated sterilizer using steam as the sterilizing agent. A computerized control unit ensuring a fully automatic sterilization cycle, control and monitoring of physical parameters and a clear documentation of the sterilization cycle controls the autoclave.

The autoclave has three automatic programs, according to the material to be sterilized, and one auxiliary drying program. Models EA and EKA are equipped with an air compressor that during the drying stage, draws air through a HEPA filter (0.2 μ m.) and pushes that air through the heated chamber to remove moisture and facilitate the drying operation. Drying is performed with the door closed.

On all models (except 1730), a water pump is installed between the water reservoir and the chamber. This pump guarantees fast and accurate filling of the chamber every time. Entry of water may be accompanied by a noise for approximately 30 seconds. This is normal noise generated by regular operation of the pump.

The control system provides adequate protection, to ensure the safety of personnel and reliable operation with a minimum of shut down time.

On all models (except 1730), a printer is an optional addition to the autoclave. The printer prints the preset and actual parameters of the cycle (temperature, time and pressure).

This manual is intended for the user and gives the user a general understanding of the instrument and the best ways to operate and take care of it in order to obtain optimum effective results.

After reading this manual, operating the autoclave will be easy. However since this instrument is built with high technology sensitive components, no attempt should be made by the user or any other unauthorized person to repair or recalibrate it.

Only technical personnel having proper qualifications and holding technical documentation (including a technician manual) and adequate information are authorized to service the apparatus.

2.2 **Stand - by heating mode**

The autoclave provides an option of heating the chamber in stand-by mode between cycles with a very low power in order to reduce total cycle time (1.6% of the total power only). The autoclave turns off automatically if the interval between the sterilization cycles is more than 2 hours. This feature is standard on all EK, EKA models and optional on all E, EA models.

2.3 **Environment Emission Information**

1. The peak sound level generated by the autoclave is less than 70 dBA with background noise of 60 dBA.
2. The total heat per hour transmitted by the autoclave is < 100 Wh for all models.

2.4 *Operating Conditions*

This device is to be used for indoor use.

This autoclave is intended for NORMAL environment conditions as follows:

- - Altitude up to 2000m.
- - Room temperature range 5°C to 40°C.
- - Installation Category II.
- - Pollution Degree 2.
- - Maximum relative humidity 80% for temperature up to 31°C decreasing linearly to 50% relative humidity at 40°C.
- - Mains supply voltage fluctuations up to +/-10% of the nominal voltage.

The sterilizer should be loaded only with autoclavable material.

Caution!

Waste water should be brought into the public net in accordance with the local rules or requirements i.e.

ONLY NON-HAZARDOUS LIQUIDS SHALL BE DISPOSED IN PUBLIC SEWAGE!



2.5 *Utilities*

Utilities	Unit	Value
Power supply (as appropriate)	V-A	1ph, 120V – 16A,50/60 Hz
	V-A	1ph, 230V – 16A,50/60 Hz

Attention:

The electrical net must be protected with a current leakage safety relay.
The electrical network must comply with local rules or regulations.



2.6 *Construction*

The main parts of the autoclave are made of materials as indicated below:

- ◆ Chamber is electro-polish and built of stainless steel 316 L.
- ◆ Door is made of stainless steel CF8.
- ◆ Trays are made of stainless steel 316.
- ◆ Water reservoir is made of hard plastic material.
- ◆ Door handle is made of hard plastic material, which is safe to touch and thermo-insulated.
- ◆ Covers are made of aluminum sheet, coated with Epoxy paint.

2.7 *Symbol Description*



Caution! Consult accompanying documents



Caution! Hot surface.



Caution! Hot steam.



Protective earth (Ground)



Stand by

2.8 *Electrical Data*

	1730	2340	2540		3545	3850	3870
	E	E, EA	E, EA	EK, EKA	E	E, EA	E, EA
Ampere (A) at 230/240V	4.6	6	6	9.6	10.4	10.4	13
Ampere (A) at 120V	8.8	11.7	11.7	—	20.0	—	—
Watts (W)	1050	1400	1400	2200	2400	2400	3000
Frequency	50 / 60 Hz						
Degree of protection by enclosure	IP31						

DESCRIPTION	AUTOCLAVE TYPE													
	1730		2340 / 2540						3545 / 3850 / 3870					
	E		E		EA		EK		EKA		E		EA	
	120V	230V	120V	230V	120V	230V	120V	230V	120V	230V	120V	230V	120V	230V
Circuit breaker (A)	15	10	15	10	15	10	—	15	—	15	—	15	—	15
Air pump fuse (A)	—	—	—	—	2.0	1.25	—	—	—	1.25	—	—	—	1.25
Water pump fuse (A)	—	—	1.25	1.25	1.25	1.25	—	1.25	—	1.25	—	1.25	—	1.25

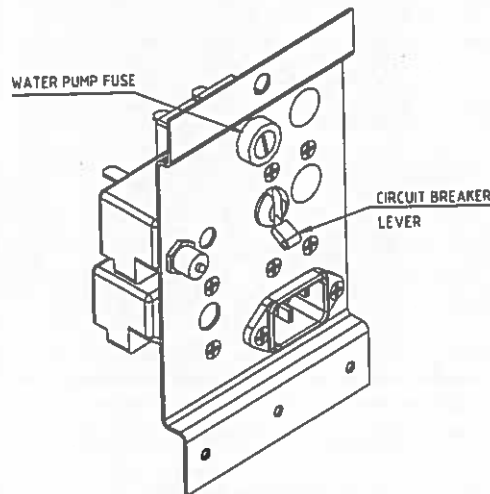

**For autoclaves
Models E, EK
(without an air pump)**

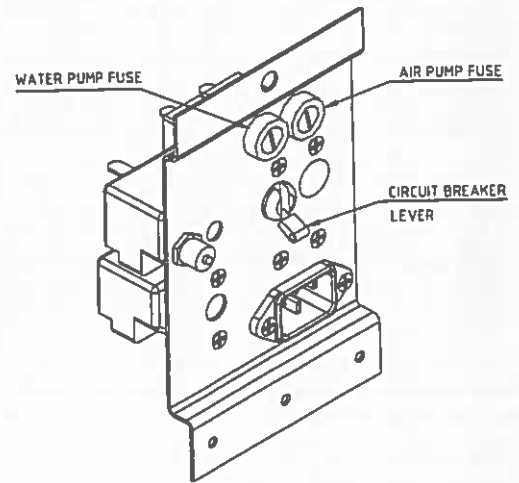

**For autoclaves
Models EA
(with an air pump)**

2.9 Specifications

Overall Dimensions

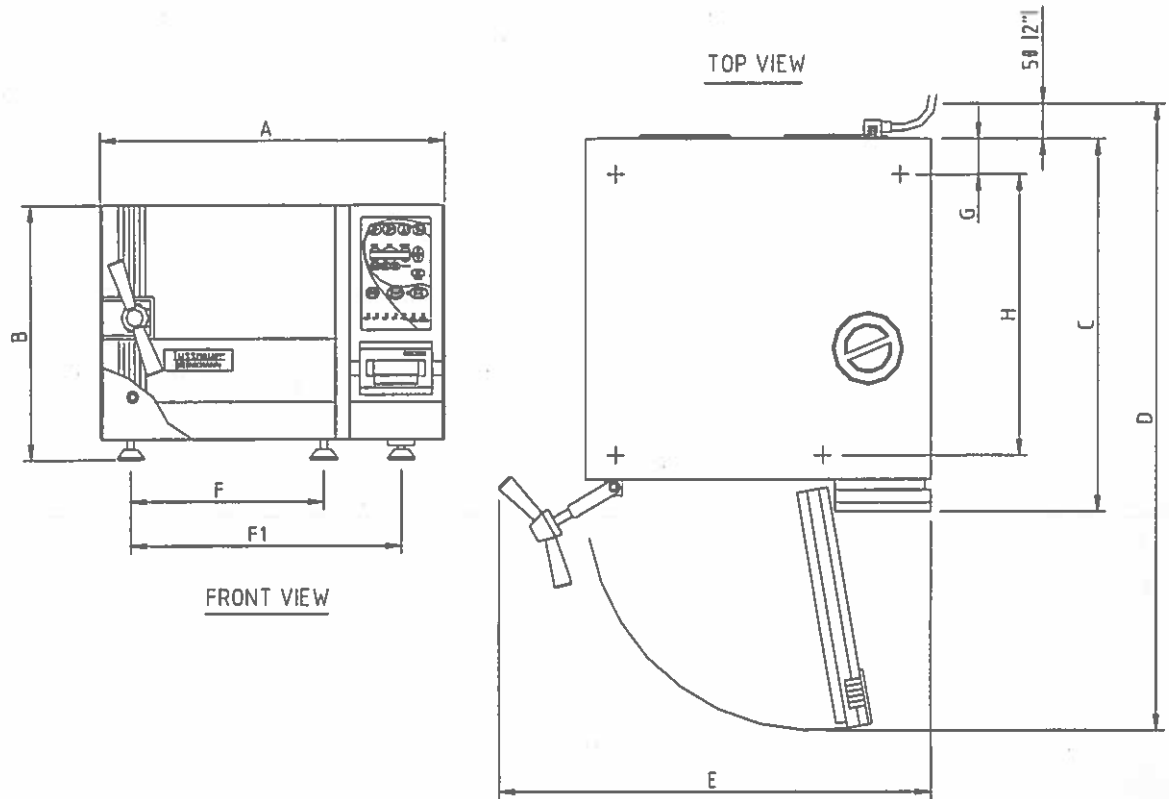

Model	1730		2340		2540		3545		3850		3870		
	mm	in	mm	in	mm	in	mm	in	mm	in	mm	in	
Overall Dimensions	A	440	17.4	510	20.0	510	20.0	590	23.2	660	26.0	660	26.0
	B	305	12.0	365	14.4	365	14.4	450	17.7	525	20.7	525	20.7
	C	455	17.9	540	21.5	545	21.5	566	21.9	695	27.5	875	34.5
Maximum dimensions (door open)	D	750	29.5	910	35.8	910	35.8	990	39.0	1155	45.5	1335	53.0
	E	560	22.0	630	24.8	655	25.8	755	29.7	815	32.0	815	32.0
Distance between supporting legs	F	350	13.8	415	16.4	415	16.4	488	19.2	450	2.0	450	2.0
	F1	339	13.4	422	16.6	422	16.6	371	14.6	564	22.2	564	22.2
	G	50	2.0	50	2.0	50	2.0	50	2.0	50	2.0	50	2.0
	H	315	12.4	400	15.8	400	15.8	400	15.2	555	2.0	725	2.0
Reservoir volume	3 lit.	0.8 gal	3 lit.	0.8 gal	3 lit.	0.8 gal	3.0 lit.	0.8 gal	6 lit.	1.6 gal	6 lit.	1.6 gal	
Minimum water vol. in Reservoir	0.8 lit.	0.21 gal	0.8 lit.	0.21 gal	0.8 lit.	0.21 gal	0.8 lit.	0.21 gal	2.0 lit.	0.53 gal	2.0 lit.	0.53 gal	
Max. Allowable Working Pressure (MAWP)	2.76 bar (40 psi)												
Load No. counter	Counting from 0 to 250 and nullifies.												

2.10 Technical Specifications

Models	Chamber dimensions DIA x D	Volume of chamber	Tray dimensions W X D X H	No. of trays	No. of EMS Cassettes (Optional)		Printer	Shipping Weight	Shipping Volume
					Full	Half			
1730	17 x 34 cm (7" x 13")	7.5 l. (2 US gal.)	12 x 29.5 x 2 cm (4.7" x 11.6" x 0.8")	3	-	2	N/A	25 kg. (55 lbs.)	0.18 m ³ (6.35 cu.ft.)
2340	23 x 47 cm (9" x 18")	19 l. (5 US gal.)	17 x 41.5 x 2cm (6.7" x 16.3" x 0.8")	3	2	2	Yes	36 kg. (79 lbs.)	0.27m ³ (9.4 cu.ft.)
2540	25.4 x 47.5cm (10" x 19")	23 l. (6 US gal.)	17 x 41.5 x 2 cm (6.7" x 16.3" x 0.8")	4	3	3	Yes	48 kg. (106 lbs.)	0.27m ³ (9.4 cu. f.)
3545	31.3 x 39.1 (12" x 15")	34.4 l. (7.8 gal.)	25.6 x 40.8 x 2.5 (10.1 x 16.1 x 1) 19.8 x 40.8 x 2.2 (7.8 x 16.1 x 1)	2	4	4	Yes	60 kg. (132 lbs.)	0.35 m ³ (12.4cu.f.)
3850	38 x 58 cm. (15" x 23")	65 l. (17US gal)	28 x 50 x 2.5 cm (11" x 20 " x 1") 35 x 50 x 2.5cm (14" x 20 " x 1")	2	10	-	Yes	89 kg. (196 lbs.)	0.63 m ³ (22.2cu.f.)
3870	38x76 cm (15" x 30")	84 l. (22 US gal)	28 x 67 x 2.5cm (11" x 26" x 1") 35 x 67 x 2.5 (14" x 26" x 1")	2	15	-	Yes	102 kg. (225 lbs.)	0.76m ³ (26.8cu.f)

2.11 Directives and Standards

Every autoclave meets the provisions of the following Directives and is constructed in compliance with the following Standards:

2.11.1 Technical Directives

1. Medical device directive MDD/93/42/EEC.

2.11.2 Technical Standards

1. A.S.M.E. Code, Section VIII div.1 for unfired pressure vessels.
2. AAMI/ANSI ST-55:2001 Table-Top steam sterilizers.
3. UL61010-1 Safety for Electrical Equipment for Measurement, Control, and Laboratory Use, General Requirements.
4. UL61010-2-041 Particular Safety for Autoclaves.

2.11.3 Quality standards

The manufacturing plant meets the following quality standards:

1. EN ISO 9001:2000– Quality System
2. ISO 13485 – Quality systems – Medical devices – Particular requirements for the application of ISO 9001.

2.12 Water quality

The distilled or mineral – free water supplied to the autoclave should have the physical characteristics and maximum acceptable level of contaminants indicated in the table below:

**Physical Characteristics and Maximum acceptable contaminants levels in steam for sterilizers
(According to EN 13060:2004).**

Element	Condensate – allowable content
Silicium oxide. SiO ₂	≤0.1 mg/kg
Iron	≤0.1 mg/kg
Cadmium	≤0.005 mg/kg
Lead	≤ 0.05 mg/kg
Rest of metals except iron, cadmium, lead	≤0.1 mg/kg
Chloride (Cl)	≤0.1 mg/kg
Phosphate (P ₂ O ₅)	≤0.1 mg/kg
Conductivity (at 20°C)	≤3 µs/cm
pH value (degree of acidity)	5 to 7
Appearance	Colourless clean without sediment
Hardness (Σ Ions of alkaline earth)	≤0.02 mmol/l

Compliance with the above data should be tested in accordance with acknowledged analytical methods, by an authorized laboratory.

Attention:

We recommend testing the water quality once a month. The use of water for autoclaves that does not comply with the table above may have severe impact on the working life of the sterilizer and can invalidate the manufacturer's guarantee.

FRONT VIEW, MODEL 1730

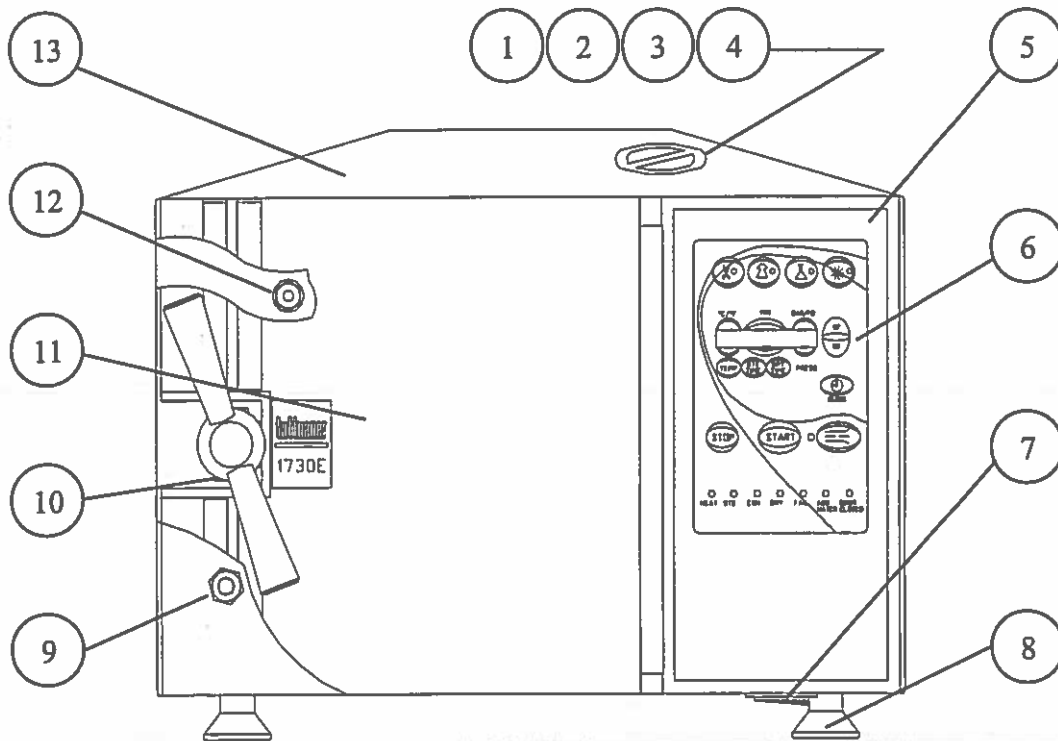

No.	Description	No.	Description
1.	Water reservoir cover	8.	Front leg
2.	Water reservoir – assembly	9.	Reservoir water drain valve
3.	Safety valve	10.	Door closing device
4.	Air relief valve	11.	Door switch
5.	Panel base	12.	Door switch
6.	Front panel key board	13.	Autoclave cover
7.	Main switch		

FRONT VIEW MODELS 2340/2540

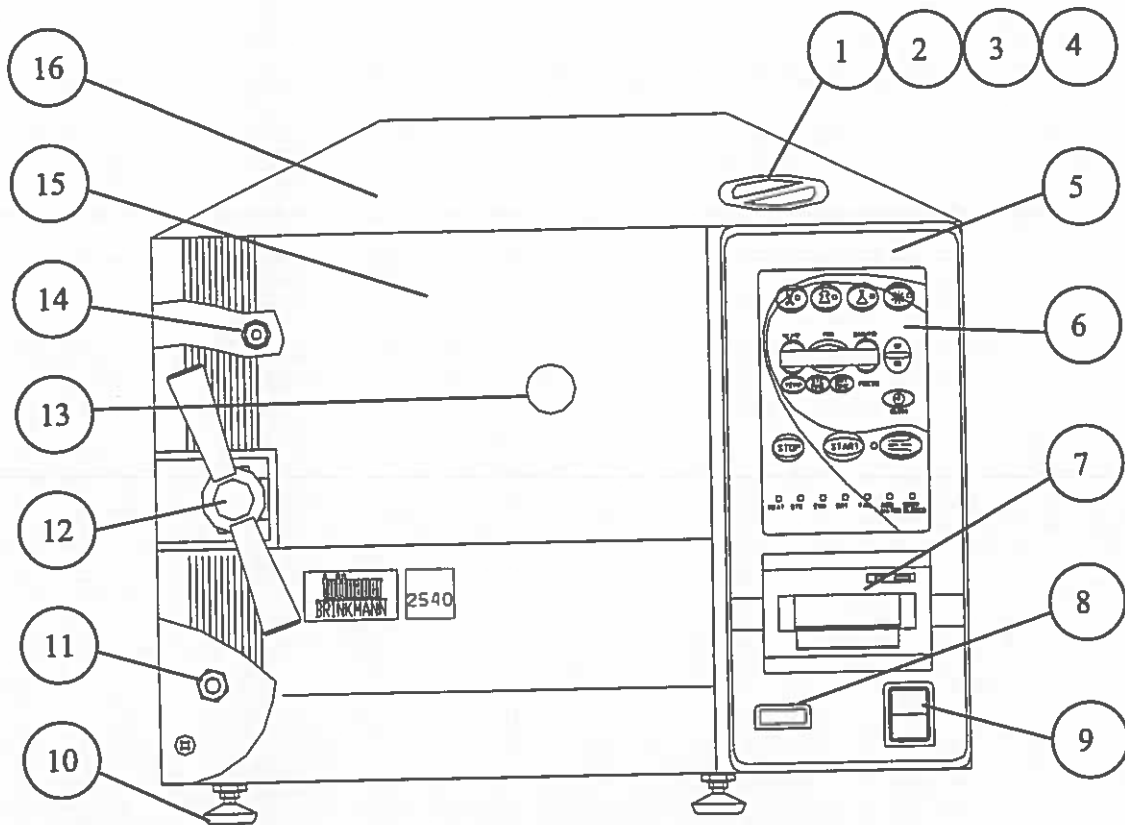

No.	Description	No.	Description
1.	Water reservoir cover	9.	Main switch
2.	Water reservoir – assembly	10.	Front leg
3.	Safety valve	11.	Reservoir water drain valve
4.	Air relief valve	12.	Door closing device
5.	Panel base	13.	Validation port cover
6.	Front panel key board	14.	Door switch
7.	Printer	15.	Door cover
8.	RS232 port cover	16.	Autoclave cover

FRONT VIEW MODELS 3545/3850/3870

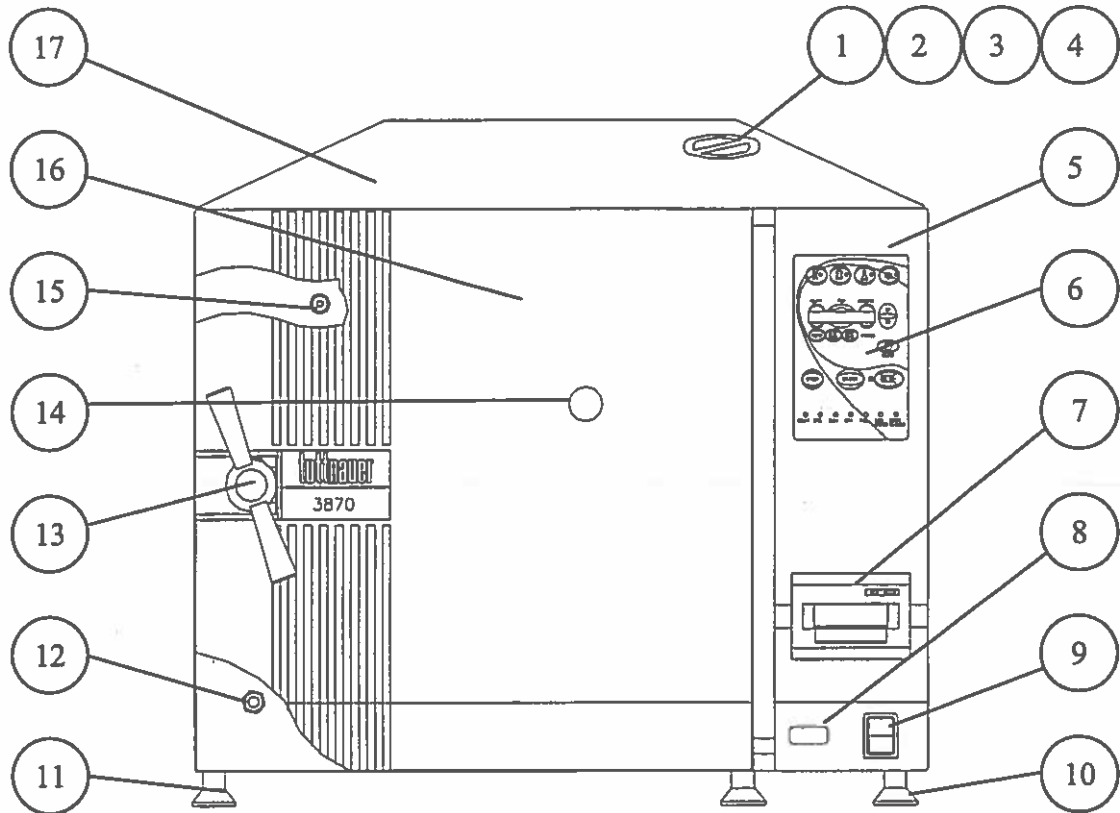

No.	Description	No.	Description
1.	Water reservoir cover	10.	Rear leg
2.	Water reservoir – assembly	11.	Front leg
3.	Safety valve	12.	Reservoir water drain valve
4.	Air relief valve	13.	Door closing device
5.	Completion to panel	14.	Validation port cover
6.	Front panel key board	15.	Door switch
7.	Printer	16.	Door cover
8.	RS232 port cover	17.	Autoclave cover
9.	Main switch		

REAR VIEW

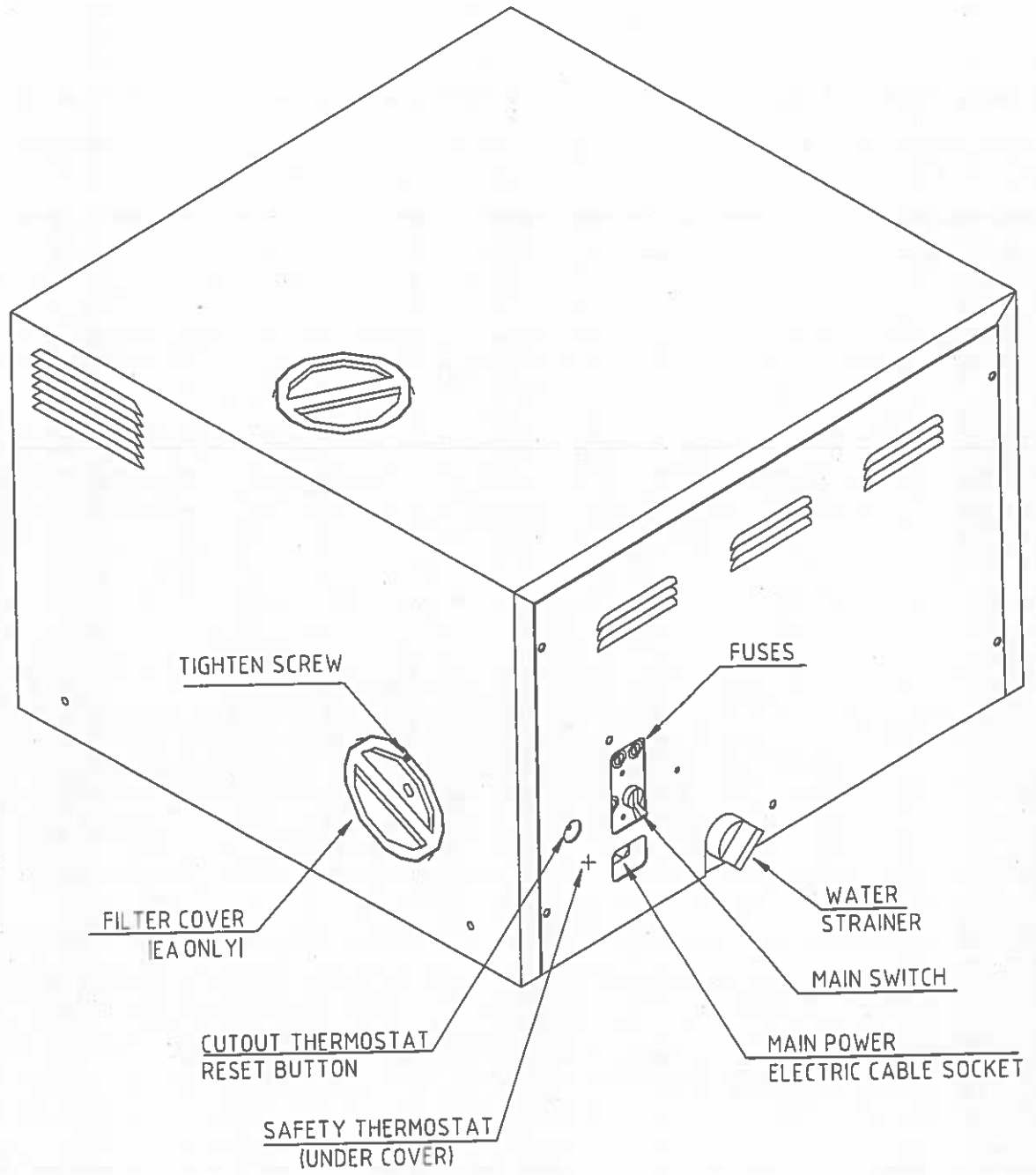

3. **KEYBOARD** (*keys and display*)

FRONT PANEL KEYBOARD

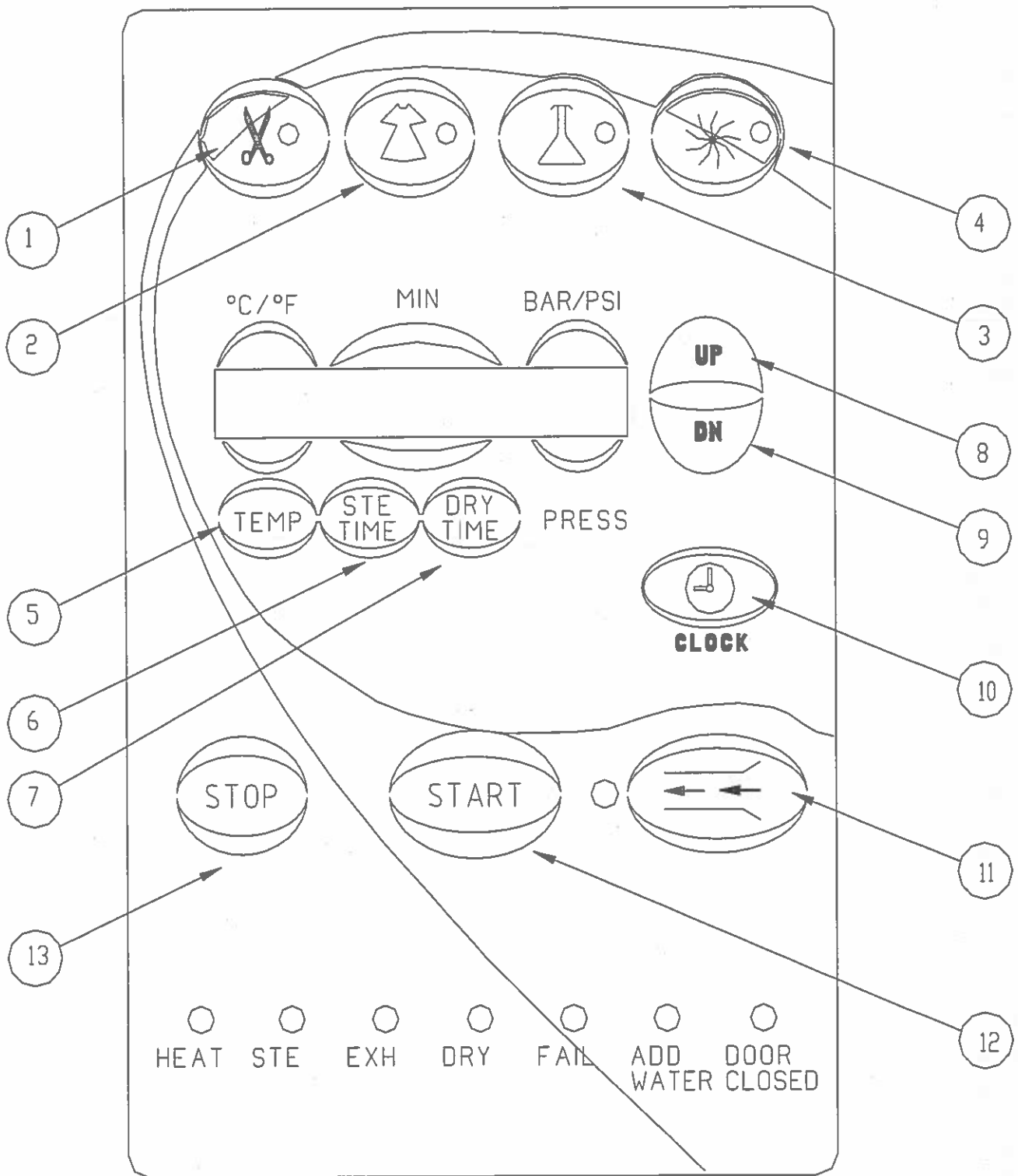

3.1 Indicator Light Description

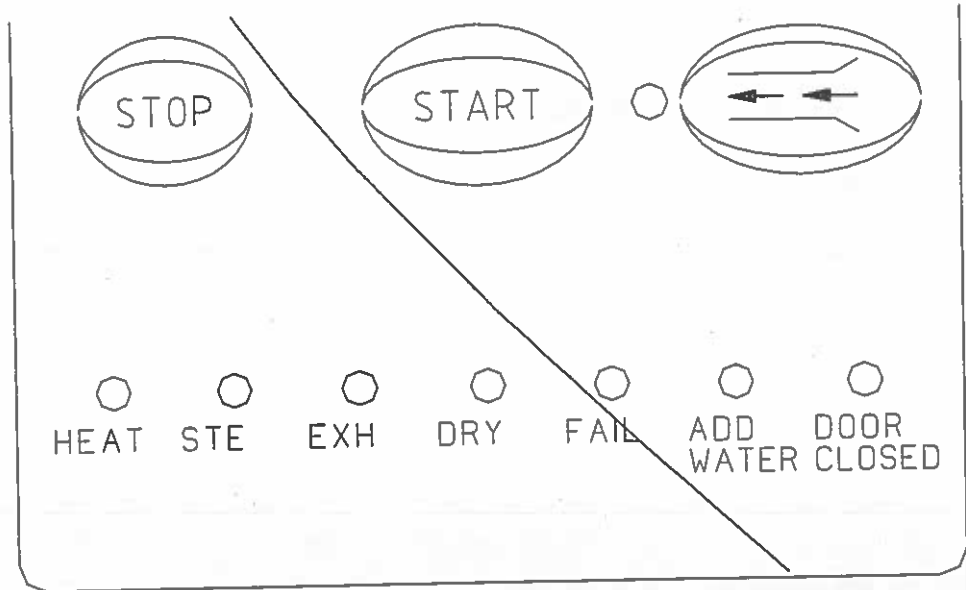

Programs Indicators	Shows the selected program
START	Shows the system is running a program
HEAT	The system is currently in the Heating stage
STE	The system is currently in the Sterilization stage.
EXH	The system is in the Exhaust stage.
DRY	The system is in the Dry stage.
FAIL	Shows the system has failed as a result of either a malfunction, or the STOP key was pressed. A message is displayed on the screen; the reason for failure.
ADD WATER	This indicator lights if there is a lack of water in the reservoir.
DOOR CLOSED	This indicator lights showing the door is in the closed position.

3.2 Description and Functions of the Control Panel Keyboard

3.2.1 Program keys

(1) Unwrapped Instruments 

(2) Wrapped Instruments 

(3) Glassware s (slow exhaust, no drying) 

Pressing one of the above program keys determines the chosen program. The program parameters are displayed and the program indicator lights.

(4) Dry Only 

Pressing this key allows inclusion of the Additional Drying procedure for a period of time determined by the operator. Time range is 0-99 minutes.

3.2.2 Other keys

(5) TEMP. 

Pressing this key places the marker under the temperature displayed on the display. To raise or lower the program sterilization temperature, press UP or DN keys. To store the new value in the memory, as the nominal setting, complete the changing of the parameter by pressing TEMP. key again. The permitted temperature range for proper sterilization is 250°F-274°F (121°C-134°C).

Note:

In no case should the temperature be set higher than 274°F (134°C)

(6) STE. TIME 

Pressing this key places the marker under the sterilization time displayed on the display. To raise or lower the program sterilization time, press the UP or DN keys. To store the new value in the memory, as the nominal setting, complete the changing of the parameter by pressing STE. TIME key again. Time range is 3-99 minutes.

Note:

It is important to properly coordinate the STE. TIME with the sterilization temperature.

(7) DRY TIME 

Pressing this key places the marker under the drying time displayed on the display. To raise or lower the program drying time, press the UP or DN keys. To store the new value in the memory, as the nominal setting, complete the changing of the parameter by pressing DRY TIME key again. The time range is 0-99 minutes. This key does not allow any change of the dry time for the Glassware program, for which it is permanently set to 00 minutes.

(8) UP 

Pressing this key in combination with TEMP. (5), STE TIME (6), DRY Time (7) and CLOCK (9) increases these values.

(9) DN 

Pressing these keys in combination with **TEMP.** (5), **STE TIME** (6), **DRY Time** (7) and **CLOCK** (9) lowers these values.

(10) **CLOCK** 

Pressing the **CLOCK** programming key displays the date, with the cursor under the day. Pressing the **UP** or **DN** keys changes the date. Pressing the **CLOCK** key again moves the cursor to the month, then year and then time (hour, minute, second). At this point the display shows the currently set date and time. If no key is pressed during a 10-second interval, the system exits the clock-programming mode and returns to the current program display.

(11) **Water Inlet** 

Pressing this key continuously, allows for manual filling of the chamber with water. Once the key is released the water pump stops, the fill valve closes and water stops entering the chamber.

(12) **START** 

Pressing this key starts the sterilization (or **DRY ONLY**) process according to the selected program. Water flows automatically into the chamber, **HEAT** and **STE.** stages commence and the respective **LED** indicator lights up.

On completion of the sterilization program the Exhaust stage will automatically begin, at the end of which a Drying stage (if previously programmed) will initiate. The respective **LED** indicators light up indicating which stage is operating. Once all stages have been completed the final indicator extinguishes and the screen displays the "Cycle Finished" message.

The process will not start if:

- The door is not closed and the **DOOR CLOSED** indicator is off.
- The "**DOOR UNLOCK**" message is displayed.

Note:

Due to inherent elasticity of the door gasket, the **CLOSE DOOR** indicator may be illuminated green before a complete seal is made between the door and the chamber. Therefore, in order to ensure the door is fully sealed, tighten the door bolt until 'hand tight'. Do not overtighten the bolt as this may result in damage to the gasket. Should the autoclave fail to reach sterilizing temperature/pressure, always check first the door is fully sealed. If not, tighten the door further, as described above, until completely sealed.

- There is not enough water in the reservoir, (the red **ADD WATER** indicator lights and the "**ADD WATER**" message is displayed).

(13) STOP

This key issues the only command accepted by the system during the running of a program. Pressing this key for over 1 second causes the program to immediately cease running and enters the EXHAUST stage, at the end of which the "MAN. STOP" message will be displayed. This key has no function when the system is not in operation and its only use is to manually stop a cycle. In normal working conditions on completion, the system automatically terminates the cycle, without use of this key.

The STOP key does not function in EXH stage.

3.3 *Description of the Display Panel*

The display is comprised of 16 characters in one row and is divided into 4 sections.

The first section to the right continuously shows the actual pressure within the chamber. This happens whether the system is running a program or not (provided the main power switch is turned on).

The three other sections are designated to show the parameters of the selected program, or operating messages. When the system is running a sterilization program, the sterilization temperature will be displayed above the TEMP key. Sterilization time will be displayed above the STE. TIME key and the drying time for the selected program will be displayed above the DRY TIME key.

If the program is aborted as a result of parameters exceeding the controlled limits (high, low pressure or temperature etc.) or a manual STOP command, a message is displayed on the left side of the screen. When a message is displayed, pressing any key erases the message and redisplay the selected program screen.

When the system is running a program, the screen displays the current temperature within the chamber and the remaining time for sterilization or drying. The current real pressure inside the chamber is always displayed on the screen.

3.4 *Description of Displayed messages and Safety Measures*

Low Heat Message is displayed and sterilization does not start if the autoclave has not reached sterilization temperature after heating for 50 minutes while in the Wrapped or Unwrapped programs (80minutes in the Liquid program).

Possible causes:

- ◆ A clogged Air Jet (see cleaning the Air Jet sec 9.3)
- ◆ No power to the heating elements
- ◆ Low line voltage delaying heat up

Low Pres Message is displayed, fail indicator lights, and the program is aborted if the pressure drops 4 psi (0.27Bar) below the required sterilization pressure.

Possible causes:

- ◆ Insufficient water in the chamber (see Low Water message)
- ◆ A damaged heating element
- ◆ A damaged pressure transducer

Low Temp. Message is displayed, fail indicator lights and cycle is aborted, if the temperature drops 2.5°C (4.5°F) below the required sterilization temperature.

Possible causes:

- ◆ Insufficient water in the chamber (see Low water message)
- ◆ Sterilization time has been set for too long a period
- ◆ A bad temperature sensor

High Temp. Message is displayed, fail indicator lights and program is aborted if one of the following occurs:

- ◆ The temperature rises to 3°C (5°F) above the required sterilization temperature during the sterilization stage.
- ◆ This message appears during the HEAT stage, if the temperature sensor is damaged.

Possible causes:

- ◆ A damaged solid state relay
- ◆ A damaged heating element
- ◆ A damaged temperature sensor

Low Water Message is displayed if during the Water Inlet stage insufficient water enters the chamber. In units with water pumps, the pump will try three times to fill the chamber with water if unsuccessful the cycle is aborted and the message LOW WATER is displayed.

Message is displayed if during a normal heat up stage the system determines that there is insufficient water in the chamber to complete the cycle. This determination is made by the combined input of two sensors, the Water Electrode and the Safety Thermostat. Also if a power failure occurs during the heat or sterilization stage after the power returns the system will check the Water Electrode to see if there is sufficient water in the chamber in order to resume the cycle. If not the cycle will be aborted, the message LOW WATER will be displayed, and the Cycle Fail indicator will light.

Possible causes:

- ◆ A dirty or shorted Water Electrode
- ◆ A clogged water pump or water pump filter
- ◆ A clogged water line
- ◆ Unit is improperly leveled
- ◆ The Air Outlet Valve is stuck closed
- ◆ A leaky door gasket, door bellows, solenoid valve, safety valve, or the air jet is allowing steam to escape at a higher than normal rate.
- ◆ A power down has occurred and on power up the water electrode tip is dry

- Door Unlock** Message is displayed and the DOOR CLOSED LED indicator remains unlit, if the door is improperly closed when the START button is pressed. If the door accidentally opens during any stage of the cycle, the same message appears, the DOOR CLOSED LED indicator will turn off, and the system reacts as if the STOP key was pressed.
- High Pres.** Message is displayed, fail indicator lights up, and the program is aborted if the pressure rises 10psi (0.6Bar) above the required sterilization pressure.
- Possible causes:*
- ◆ A damaged solid state relay
 - ◆ A damaged heating element
- Man. Stop** Message will be displayed and the FAIL indicator will light after the STOP key is pressed for longer than 1 second.
- Add Water** Message is displayed and the respective red LED indicates insufficient water in the water RESERVOIR. After water is added to the reservoir, the START button must be pressed again in order to start the required sterilization cycle.
-
- Water Inlet** During the automatic water fill, the message WATER INLET is displayed, as information to the operator.
- Power Dn.** If a power failure occurred during the running of a cycle, when power resumes a POWER DN message is displayed for several seconds, if a printer is installed it will print POWER DN. In addition the system automatically attempts to complete the STERILIZATION stage if the following parameters are met:
- a. If the temperature drop is less than 2.5°C (4.5°F), sterilization resumes automatically.
 - b. If the temperature drop is more than 2.5°C (4.5°F), the cycle fails, POWER DN message is displayed and printed and LOW TEMP message is displayed.
 - c. If the pressure drop is more than 4psi (0.27Bar), the cycle fails, POWER DN message is displayed and printed and LOW PRES message is displayed.
- If a power failure occurred during the HEAT stage, heating resumes, provided enough water remains in the chamber. If not, the cycle is aborted, the message "LOW WATER" is displayed. If a power failure occurs during the dry and exhaust stages, the unit will automatically resume operation once the power is back on.
- If a power failure occurs during the LIQUIDS PROGRAM, the system does not allow fast exhaust (as the exhaust valve is normally closed) during a power failure or when power resumes.
- CYC Finish** When the cycle has been completed successfully the message CYC FINISH is displayed.

4

STERILIZATION PROGRAMS

The autoclave offers 3 sterilization programs, at a temperatures of 121°C (250°F), with or without a drying stage and 1 accessory (dry only) program.

A. Three sterilization programs:

1. Unwrapped instruments
2. Wrapped instruments and porous loads.
3. Liquids

B. Accessory program:

4. Dry only

Note:

The nominal data of the program (default settings) can be changed to fit the needs of a particular office. This is done by means of the **TEMP, STE.TIME, DRY TIME,** keys in combination with the **UP** or **DN** keys, as described in sec 3.2.2.

4.1 PROGRAM 1. Unwrapped Instruments

For unwrapped instruments and materials, when the manufacturer recommends autoclaving at temperature of 121°C (250°F) no preset drying stage required.

Nominal parameters default settings

- ◆ Sterilization temperature: 121°C (250°F)
- ◆ Sterilization time: 15 minutes.
- ◆ Dry time: none

Operations Sequence

- ◆ Heating by actuation of electrical heaters until the sterilization temperature is reached.
- ◆ Sterilization temperature is maintained constant for the preset sterilization time.
- ◆ Fast exhaust, steam is exhausted out of the chamber at a fast rate until pressure drops to zero.

Note:

The sterility of instruments processed in unwrapped cycles cannot be maintained if exposed to non-sterile environment.

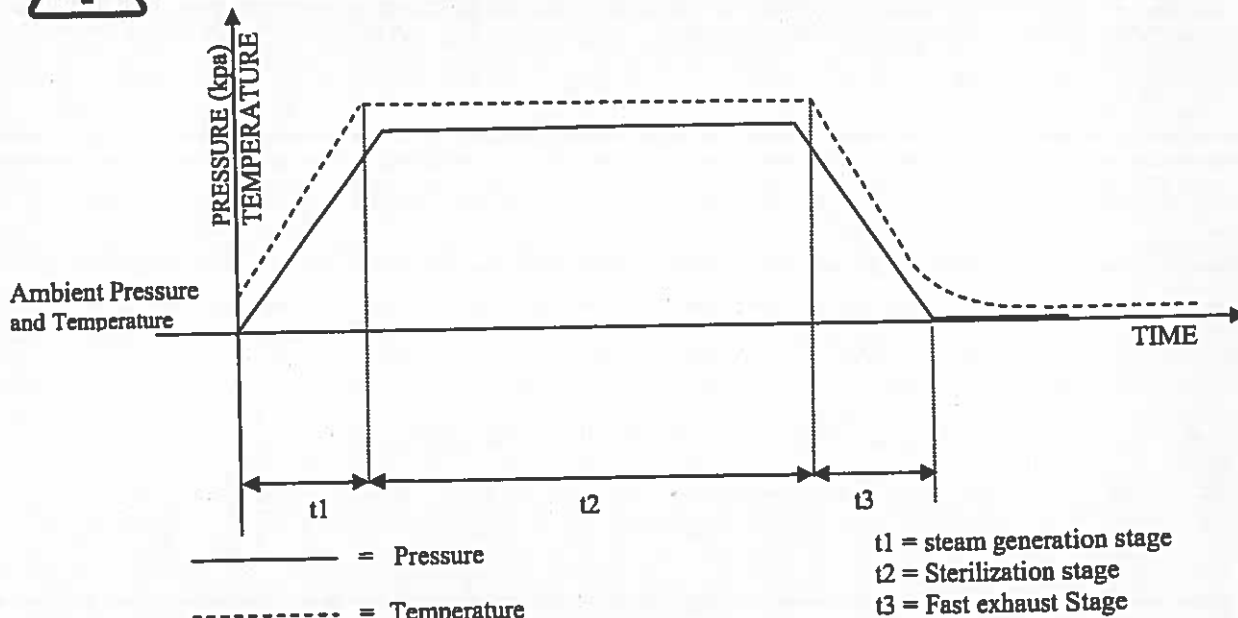

4.2 PROGRAM 2 . *Wrapped Instruments and Porous Loads*

For wrapped instruments and materials, when the manufacturer recommends autoclaving at temperature of 121°C (250°F) with a drying stage.

Nominal parameters default settings

- ◆ Sterilization temperature: 121°C (250°F)
- ◆ Sterilization time: 15 minutes
- ◆ Dry time: Models EA – 30 minutes.
 Models E/EK – 60 minutes.

Operations sequence:

- ◆ Heating by actuation of electrical heaters until the sterilization temperature is reached.
- ◆ Sterilization temperature is maintained constant for the preset sterilization time.
- ◆ Fast exhaust, steam is exhausted out of the chamber at a fast rate until pressure drops to 4 psi abs. (124 kpa abs.).
- ◆ Dry heating of chamber to remove leftover moisture from the instruments and wraps, 30 minutes for models EA and 60 minutes for models E/EK.

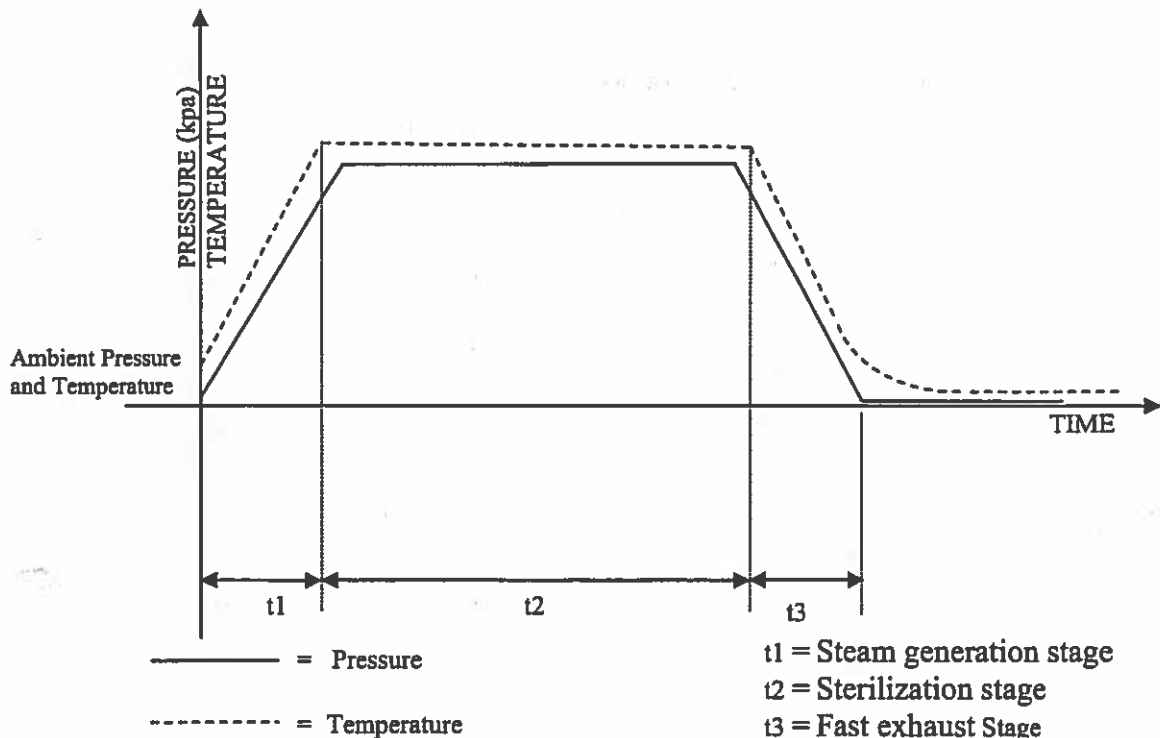

4.3 PROGRAM 3: Liquids

For distilled water, solutions, medicines and other liquid preparations in closed bottles or flasks.

Nominal parameters default settings

- ◆ Sterilization temperature: 121°C (250°F).
- ◆ Sterilization time: 30 minutes.
- ◆ Slow exhaust: 15 to 20 minutes.
- ◆ Drying time: drying is not allowed.

Operations sequence:

- ◆ Heating by actuation of electrical heaters until the sterilization temperature is reached.
- ◆ Sterilization temperature is maintained constant for the preset sterilization time.
- ◆ Slow exhaust, heating is stopped and steam is let out of the chamber at a slow rate until the temperature decreases to 85°C (185°F).
- ◆ No drying is allowed

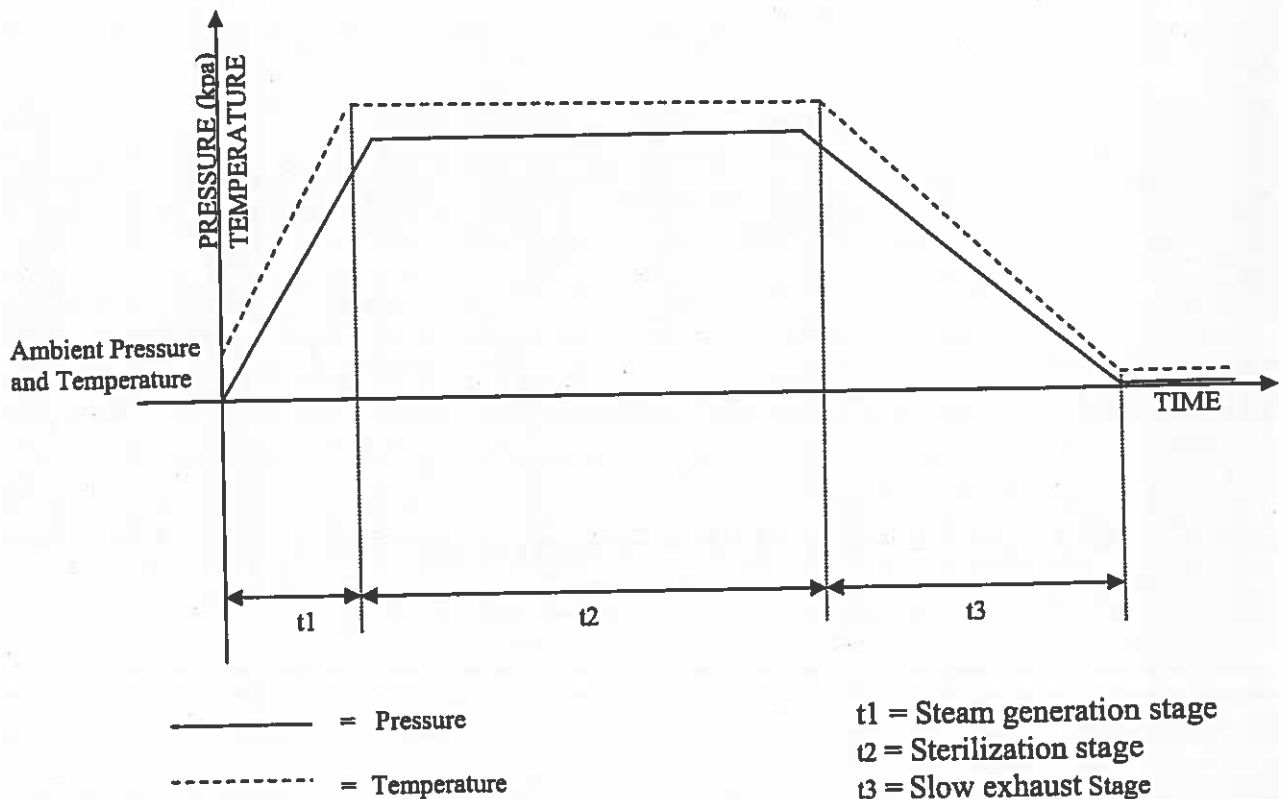

4.4 PROGRAM 4: Accessory (Dry Only)

The purpose of the accessory drying program is to offer an alternative in situations where the dry time in the wrapped or unwrapped cycle is insufficient. Rather than wait for the items to air dry or run another complete cycle with a longer dry time, just select the accessory drying program to continue the heat assisted drying process.

5 ***PRINTER (Optional)***

The printer is an optional device. If the autoclave is not equipped with a printer paragraph 5 is not applicable.

5.1 ***Printer Operation***

The autoclave is equipped with a character printer, which prints a detailed history of each cycle performed by the instrument (for the record or for subsequent consideration).

The printing is made on thermal paper with 24 characters per line and contains the following information:

- ◆ Software version
- ◆ Date and time of cycle start
- ◆ Selected program and parameters
- ◆ Sterilization pressure
- ◆ Sterilization temperature
- ◆ Sterilization time
- ◆ Cycle identification.

When the sterilization cycle begins the printer starts printing the above data.

After the preliminary printing, the autoclave starts performing the sequence of operations of the cycle. The measured values of temperature and pressure are printed at fixed time intervals, according to the phase of the process, as shown in the table below.

The data is printed from the bottom up, beginning with the program name and ending with "O.K." for a complete cycle or "FAIL" for an aborted cycle.

For an example of a typical printout, see next page.

PRINTER OUTPUT	DESCRIPTION
Autoclave No:01	Number of the autoclave with respect to other units in the same location
Load number: 0003	Load number. Useful to determine when to clean the chamber. (upon reaching 255 this number is reset to 0)
Operator : _____	To be filled in manually by operator.
O.K.	Cycle completed successfully
<hr/>	
D78 055°C 00P	The time, temperature and pressure during drying.
* * *	Prints drying data every 3 minute.
D21 104°C 00P	The time, temperature and pressure during drying.
E21 112°C 04P	The time, temperature and pressure during exhaust.
S21 121°C 17P	The time, temperature and pressure during sterilization.
* * *	Prints sterilization data every 1 minute.
S14 121°C 18P	The time, temperature and pressure during sterilization.
S13 121°C 18P	The time, temperature and pressure during sterilization.
<hr/>	
H12 117°C 14P	The time, temperature and pressure during heating.
H00 038°C 00P	The time, temperature and pressure during heating.
* * *	Prints heat up data every 4 minute.
H00 72°F 00P	The time, temperature and pressure during heating.
<hr/>	
MN TEMP PRES	
DRY: 60MIN	Drying time for selected program.
TIME: 08MIN	Sterilization time for selected program.
TEMP: 121°	Sterilization temperature for selected program.
PROG: PKG	Selected program: Unwrapped instruments
TIME: 12:57:23	Time sterilization cycle begun.
DATE: 12:05:04	Date sterilization cycle begun.
Version: T04EWP	Number and version of the program

Legend

<i>MN</i>	<i>Time elapsed in minutes</i>	<i>E</i>	<i>Exhaust stage</i>
<i>H</i>	<i>Heating stage</i>	<i>D</i>	<i>Drying stage</i>
<i>S</i>	<i>Sterilization stage</i>	<i>P</i>	<i>psi</i>

5.2 Printer Handling

The printer is driven and controlled automatically by the control unit, while the autoclave performs a sterilization program.

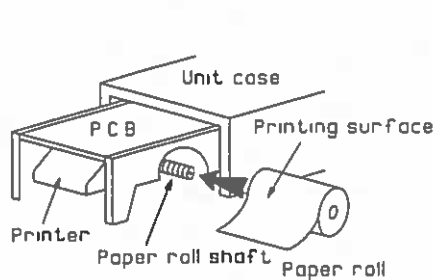

Figure 1

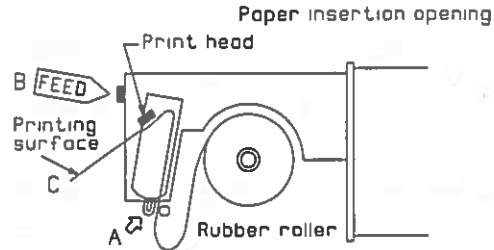

Figure 2

To set the paper roll in the printer perform the following steps:

- 5.2.1 Gently push the clips for removing the front panel, remove the panel and pull out the printer gently.
- 5.2.2 Set the paper roll on the shaft (See Figure 1). Since the outer and inner surfaces of the paper are different set the roll so that the printing surface is the outer.
- 5.2.3 Gently push the paper face down into insertion opening (A) in Figure 2. Keep pressing the feed switch (B) until the paper comes out from the print head (C).
- 5.2.4 When the paper emerges from the print head, insert it in the paper cutter (the slot in the front panel) and reassemble the front panel on the unit.

The paper roll is set inside the unit and the printer is ready for use.

NOTE: If the paper is not pulled in by the rollers even when you press the feed switch (B) push the paper in.

- 5.2.5 **To ensure a reliable operation of the printer perform the following:**
 - 5.2.5.1 Turn the main switch to the OFF position.
 - 5.2.5.2 Press the feed switch and at the same time turn the main switch to the ON position. Verify that the printer performs an operation test by printing all the built-in characters

The following precautions have to be taken ensuring the proper operation of the printer:

- ◆ Avoid contact between the paper and the hot parts of the autoclave, as the paper will be blackened.
- ◆ Do not pull out the paper roll from the paper insertion opening.
- ◆ Use only the 58mm. wide thermal paper rolls, supplied by your dealer. Larger rolls will not fit inside the printer.

6 INSTALLATION INSTRUCTIONS



Caution:

The sterilizer must be placed on a rigid and leveled surface. The stand must be able to hold the load of the device and loaded material as follows:

Model		1730	2340	2540	3140	3850	3870
Weight	lb	75	106	117	172	245	278
	Kg	34	48	53	78	111	126



Note:

Make sure while placing the autoclave, to leave space around the machine, to give the technician access to service the machine.

6.1 Electrical

The electrical connection should comply with the devices power requirement. It must also comply with local installation and safety rules and regulations. The voltage supplied to the device must comply with the label $\pm 5\%$.

In order to avoid any injury by electrical hazard, it is mandatory for the customer to have installed an earth leakage relay (GFI outlet or circuit breaker) in the electrical circuit to which the autoclave is connected. This relay disconnects all the poles of the electrical power line in case of accidental contact with the autoclave's metal enclosure, by the operator or another person, leading to a dangerous leakage current.

Note: Keep the back and the right side of the autoclave approximately 1" (25mm) away from the wall to allow for ventilation.

Connect the power cord to the socket on the rear side of the autoclave; plug it into the supply outlet.

6.1.1 Setup for new units 2340, 2540, 3545, 3850 & 3870

Your new Tuttnauer Autoclave was set at the factory and requires a minimal of setup.

- ◆ Make sure the counter is level and sturdy
- ◆ Make sure all the feet are on the autoclave and none have been lost.
- ◆ Position the autoclave on the counter
- ◆ Fill the reservoir with distilled water (see sec 6.5)
- ◆ The unit is ready to operate

6.1.2 Setup for units 1730 & any unit with serial number prior to 2003000

Proper adjustment of the chamber pitch is one of the most important things you can do for the sterilizer. Proper chamber pitch insures that among other things the sterilizer will have the proper amount of water in the chamber at the beginning of each cycle. Insufficient water in the chamber at the beginning of the cycle will generate a LOW WATER message at some point during the cycle when the water level becomes to low. If on the other hand there is too much water in the chamber this will extend the heating portion of the cycle. In cases where the heating portion of the cycle is extended for more than 50 minutes (80 minutes for a 3850/3870) the sterilizer will abort the cycle and display a LOW HEAT message. Please follow these setup steps:

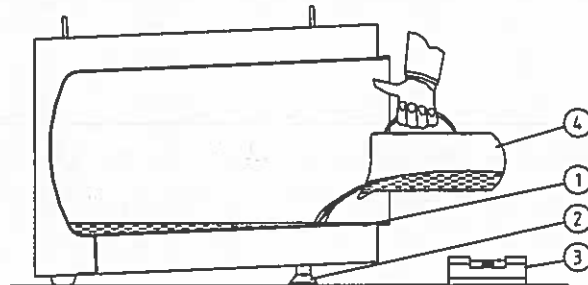

- ◆ Make sure the counter is level and sturdy (3)
- ◆ Make sure all the feet are on the autoclave and none have been lost.
- ◆ Make sure the feet are free to move in and out (2)
- ◆ Position the autoclave on the counter
- ◆ Fill the reservoir with distilled water (see sec 6.5)
- ◆ The chamber should be empty of any instruments, trays or leftover water.
- ◆ The autoclave should be turned off
- ◆ The chamber pitch now needs to be adjusted
- ◆ Measure to the proper amount of distilled water for the appropriate model unit as listed below (the tolerances on these amounts are +2 oz. and -0 oz)

1730		2340/2540		3545		3850		3870	
10 oz	300 ml	12 oz	350 ml	14 oz	400 ml	20 oz	600 ml	24 oz	750 ml.

- ◆ Pour the proper amount of water into the chamber through the front door of the unit (4)
- ◆ This water should cover the bottom of the chamber to within +/- 1/2 inch of the groove in the front. (1)
- ◆ If necessary adjust the front leveling feet so that the water lays in the chamber correctly. (2)
- ◆ Once the chamber pitch adjustment is completed, empty the water from the chamber and check if the automatic filling is set correctly. See sec 6.2.3

6.2 Automatic Water Filling

6.2.1 For new units 2340, 2540, 3545, 3850 & 3870

The proper amount of water for automatic filling in your new Tuttnauer autoclave has been preset at the factory. However, if in routine operation, there is inadequate water in the chamber, the operator can adjust the level with the automatic built-in system by doing the following.

1. Press STOP key repeatedly until the message "code xxx" appears on the display.
2. Use the UP or DN arrow keys to change the code to 105, then press the STOP key
3. A message will be displayed saying "Water in = xx sec"
4. Press UP or DN keys to increase or decrease water inlet time.
5. Press the STOP key to enter new water inlet time into memory.
6. If necessary press the STOP key again to bring up the program display.

Note:

DO NOT attempt to automatically fill the chamber with the DOOR open. Water will over flow out of the chamber.

Warning:

If it becomes necessary to RESET the software program it will be essential to repeat all steps listed above. This will ensure that the correct amount of water enters the chamber for operation.



6.2.2 For units 1730 & any unit with serial number prior to 2003000

If it becomes necessary to adjust the automatic fill then follow these steps:

1. Make sure the power is off.
2. The door should be open and the chamber empty of any water.
3. Make sure the Water Electrode is clean (see sec 9.9)
4. Press and hold the Water Inlet key (this is the button on the keypad with the two arrows). 
5. Turn the power on. When the program display screen appears release the Water Inlet key – wait one second and then press it in again.
6. Water will begin following into the chamber
7. Monitor the water flow
8. Hold the Water Inlet key until the water reaches the groove at the front of the chamber.
9. Now release the button – wait ten seconds – the unit is now reprogrammed.

6.2.3 *Checking the automatic fill*

To check the automatic fill, follow these steps:

To check the automatic fill, follow these steps:

1. Remove any water that is in the chamber.
2. Make sure the unit is turned on.
3. Place a collecting vessel under the autoclave's door.
4. With the door open, press and hold the door switch, then press the **START** key.
5. When water starts flowing into the chamber release the door switch.
6. Water should come beyond the groove at the front of the chamber, and a small amount will pour into the collecting vessel.
7. After the automatic filling is completed, tilt the autoclave and pour all the water in the chamber into the collecting vessel.
8. Measure and verify that the amount of water pumped into the chamber is 500-600 ml.
9. If the water is not filling correctly then follow the adjustment procedure above.

Warning:

*If it becomes necessary to **RESET** the software program it will be essential to repeat all steps listed above. This will ensure that the correct amount of water enters the chamber for operation.*



VERY IMPORTANT – *Due to the fact that the water lines are empty when the unit is shipped air may become trapped in the lines. It is recommended that for the first operation these steps are followed to make sure water is flowing freely.*



*Open the door, press the **Water Inlet** key. When water enters the chamber release the key and remove the water.*

6.3 *Lifting and carrying*

Caution:

Before moving the autoclave, Make sure that the electric cord is disconnected from the power and there is no pressure in the chamber.



1. Disconnect the power supply cord.
2. Drain the water from the reservoir and vessel.

To avoid injuries, lifting and carrying should be done by two people.

Do not drop this device!

6.4 Loading and unloading the Device

6.4.1 Safety

Protective equipment and clothes and other safety instructions should be implemented in accordance with local and national regulations and/or rules!

For proper sterilization - Do not overload the chamber. Only autoclavable products shall be used; please refer to the materials or instruments manufacturers instructions for sterilization of unknown materials or instruments.

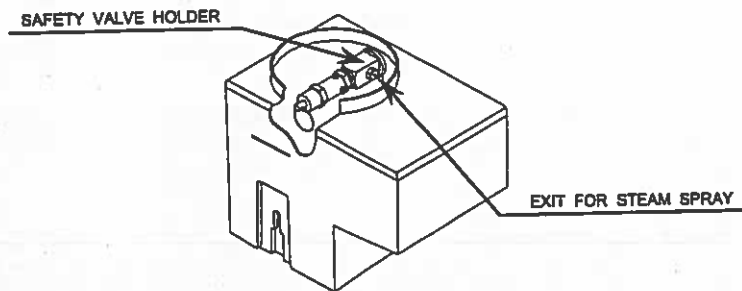

6.4.2 Loading

Correct loading of the autoclave is essential to successful sterilizing for several reasons. Efficient air removal from the chamber and the load will permit steam penetration and saturation, and allow proper drainage of condensate. Additionally, correct loading will reduce damage to packs and their contents and maximize efficient use of the sterilizer.

For detailed loading instructions, see sec. 7 (Preparation before sterilization)

6.4.3 Unloading

On completion of the cycle, the load shall be immediately removed from the sterilizer and a visual inspection made to ascertain that the load is dry, and that sterilizing indicators have made the required color change.

6.5 Filling the Water Reservoir

Remove the water reservoir cover. Pour distilled water into the reservoir through the opening on top of the autoclave until it reaches the base of the safety valve holder, approximately 0.7 gallons (3 liters).

Use water-having characteristics as per table in sec 2.11

Caution:

Under no circumstance should water be filled above the safety valve holder.



USE DISTILLED WATER ONLY. The impurities in tap water will create the need for more frequent cleaning and maintenance, in addition they will accumulate and block the hole of the Air Jet. This will prevent the temperature in the chamber from rising properly. This will cause the unit to abort its cycle, spore tests to fail and indicator strips not to change color. It is essential from time to time during heating and sterilization phases that a spray of steam should escape, from the Air Jet, causing a hissing sound. If no escaping steam is evident or no hissing sound heard then follow the instructions in sec 9.3 for cleaning the Air Jet.

7 **PREPARATION BEFORE STERILIZATION**

The purpose of packaging and wrapping items for sterilization is to provide an effective barrier against contamination during storage, once the items have been sterilized.

Instruments to be sterilized must be free from all residual matter, such as blood or organic tissue. Instruments must also be dry and free from mineral deposits. Such substances may cause damage to the instruments themselves or the Sterilizer.

1. Clean instruments immediately after use to remove any residue. It is recommended that all instruments be ultrasonically cleaned using Tuttnauer's **CLEAN AND SIMPLE** enzymatic cleaning tablets or other suitable solution.
2. After cleaning, rinse instruments under tap water for 30 seconds and pat or air dry to remove residual minerals. If your tap water has a high mineral content then rinse a second time in a bath of distilled water to remove minerals.
3. Launder textile wraps prior to reuse, but **do not** use bleach.
4. Follow the instrument manufacturer's instructions on the use of products for cleaning and lubricating instruments that have been ultrasonically cleaned.
5. Be sure that instruments of dissimilar metals (stainless steel, carbon steel, etc.) are separated. Carbon steel instruments should be bagged or placed on autoclavable towels and not directly on stainless steel trays (mixing will result in the oxidation of these metals).
6. Do not place materials to be sterilized against the chamber's wall. Place the material only on the tray or rack.
7. When using a paper / plastic bag the plastic side should always be down.
8. Check the instructions of the item manufacturer as to the proper procedure for sterilizing each item.
9. Items must be sterilized in an open position. Surfaces that are hidden because the item is in a closed position will not be exposed to the steam and will not be sterilized

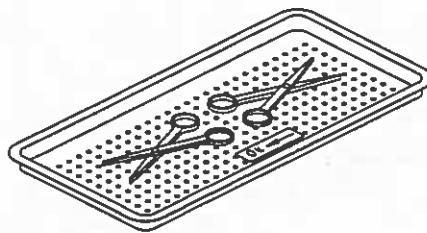

10. Place a sterilization indicator in each tray or inside each wrapped pack.
11. At least once a week use a biological spore test (*Bacillus Stearothermophilus*) in any load to insure proper sterilization. (Be aware testing standards may vary) Always follow the spore test manufacturer's instructions
12. Make sure that all instruments remain apart during the sterilization cycle. Surfaces that are hidden because items are covering other items will not be exposed to the steam and will not be sterilized
13. Verify that packaging methods are in accordance with the good practice approach and the packaging materials used are in agreement with applicable standards

14. Empty canisters should be placed upside-down in order to prevent the accumulation of water.
15. Do not overload the Sterilizer trays. Overloading will cause inadequate sterilization & drying.
16. Allow a distance of approximately 1" between trays to permit steam circulation.
17. Wrapped instruments should be placed in material which will allow steam penetration and promote drying, such as autoclave bag, autoclave paper, or muslin towels.
18. Do not stack pouches. It is recommended that a pouch rack such as the Tuttnauer **POUCH RACK** be used to insure proper steam penetration and adequate drying. Surfaces that are hidden because the items are being stacked

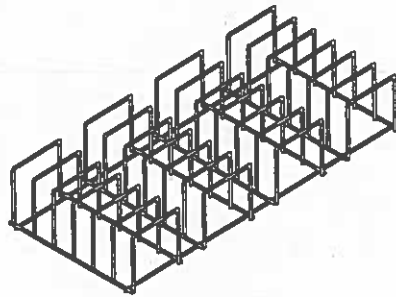

For models 2340, 2540

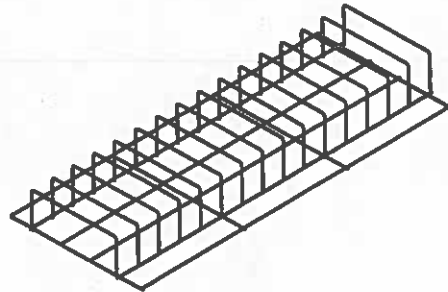

For model 3870

will not be exposed to the steam and will not be sterilized

19. Tubing should be rinsed after cleaning. When placed in the tray make sure that both ends of the tubing are open and there are no sharp bends or twists

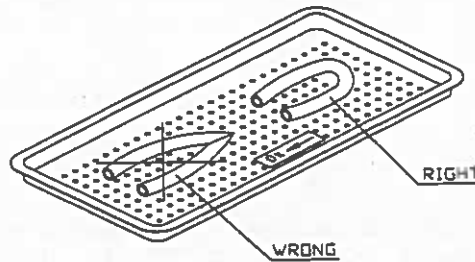

20. Packs should be placed upright on the tray. They should not be touching each other or the Chamber walls. There should be about 1" between packs for proper steam circulation.

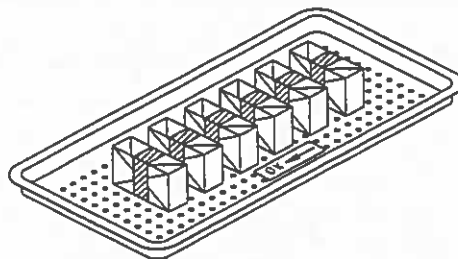

21. Liquids should only be sterilized in heat proof glass. The beaker should only be filled 2/3 full and the lid should be on loosely to allow for expansion.
22. If spotting is detected on the instruments the first step would be to use an

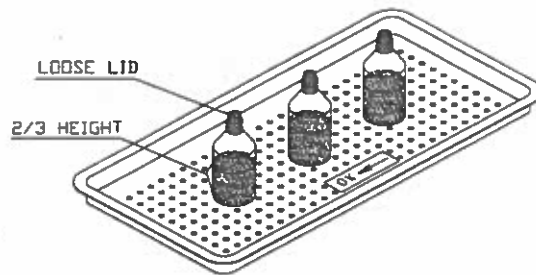

- ordinary eraser to remove the spot. If there is no pitting under the spot then the spot was only dirt. Dirt spots on an instrument may be an indication that the autoclave needs to be cleaned or that the instruments were not adequately cleaned or dried. If removal of the spot reveals pitting then the spot was most likely rust. Rust spots on an instrument are not uncommon on inexpensive instruments. It may also be an indication that the instruments were rinsed in tap water with a high content of minerals. These minerals when exposed to high temperature and steam will accelerate the oxidation of the metal. One suggestion would be to final rinse the instruments in a distilled water bath.
23. If the instruments exhibit a discoloration this can be due to the mixing of carbon steel and stainless steel. When these two metals come into contact with each other an electrolysis occurs that breaks down the metal. The best solution is to separately wrap the carbon steel to insulate it from other instruments or the trays.
 24. Items should not be allowed to touch the walls of the Chamber as the hot metal can damage the item.

8



OPERATING INSTRUCTIONS

It is important to clean the hole of the air jet, as described in sec. 9.3 before starting operation of the autoclave, for the first time.

1. Remove water reservoir cover. Pour distilled water into the reservoir, through the opening on top of the autoclave, until it reaches the base of the safety valve holder, approximately 0.7 gallons (3 liters).
2. Plug the power cord into the back of the autoclave and into the wall outlet.
3. Turn on the rocker switch mounted on the bottom of the front panel.
4. If a printer is installed then set the clock with the proper date and time.
5. Press the required key to select the required program. The light indicator of the selected program is illuminated; indicating the program has been selected. The preset data of the program, sterilization temperature, time and dry time are displayed.
6. Load the material to be sterilized into the chamber according to instructions in sec. 7 (Preparation Before Sterilization) and close the door making sure the 'Close Door' indicator is illuminated.

NOTE:

Due to the inherent elasticity of the door gasket, the CLOSE DOOR indicator light may be illuminated green before a complete seal is made between the door and the chamber.



Therefore, in order to ensure that the door is fully sealed, when the green light has been illuminated continue to tighten the door bolt until "hand tight". Do not over - tighten the bolt as this may result in damage to the gasket.

Should the autoclave fail to reach the sterilizing temperature/pressure, always check first that the door is fully sealed. If not, then tighten the door bolt further, as described above, until completely sealed.

7. Press the START key to put the autoclave in operation.

WATER INLET is displayed until the correct volume of water is automatically introduced.

The autoclave starts performing the sequence of operations. The actual measured values of pressure and temperature are displayed continuously (and printed with optional printer).

The indicator lights HEAT, STE, EXH and DRY are turned on and off as each stage is started and completed.

NOTE:

It is possible to change parameters, only when the autoclave is not in operation. In order to change the fixed preset parameters, proceed as follows:

To increase or decrease the sterilization temperature, sterilization time or dry time, follow instructions from sec. 3.2.2.

Pressing the UP/DN key, advances the setting upward or downward by one unit. The displays are updated with every change in the preset data.

8. During any program that has a drying stage scheduled, the dry stage begins after the steam exhaust stage. Models EA are equipped with an air compressor that during the drying stage, draws air through a HEPA filter (0.2µm), and pushes that air through the heated chamber and out the air outlet valve to remove moisture and facilitate the drying operation. Drying is performed with the door closed.

- 8.1 To obtain better drying results from the E models, during the dry stage open the door partially (as described below) at an angle of approx. 20-25 degrees. The heaters will be on at a lower power level and water vapor and humidity will be evacuated from the chamber efficiently.

With out moving the closing device from its position unscrew the closing device as far as it will go. Allow the door to open to the maximum that the closing device will allow (see picture).

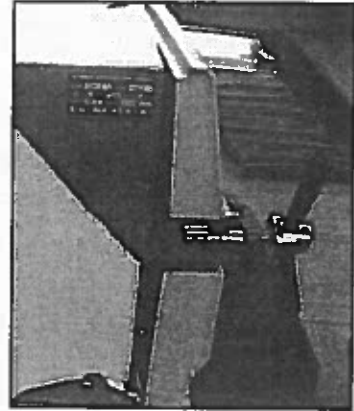

9. At the end of the cycle a buzzer rings for approximately 5 seconds, the START light switches OFF. The air outlet valve is opened to prevent formation of a vacuum.

In the event of a program failure, the exhaust valve is opened to release pressure from the chamber and a continuous buzz will sound for 5 seconds followed by an interrupted buzz of 7 seconds.

10. Open the door and unload the sterilized material from chamber.
11. The sterility of instruments processed in unwrapped cycles cannot be maintained if exposed to non-sterile environment.

Note:

A minimum time interval of 10 minutes needs to be observed between the end of a cycle and the start of a new cycle, to prevent overheating of the autoclave.

Do not touch the strainer's cover, mounted on the exhaust line, during and shortly after operation, it will get very hot.

Touching the hot strainer's cover may cause severe injuries.



MAINTENANCE INSTRUCTIONS

9 MAINTENANCE INSTRUCTIONS

9.1 Preventive and Scheduled Maintenance

The maintenance operations described in this chapter need to be followed as indicated to keep the device in good working condition.

The instructions that follow can easily be carried out by the office personnel and do not require a service technician.

Should the need arise technical assistance or a service technician can be requested by either calling your dealer or Tuttnauer USA.

9.1.1 Daily

Clean door gasket with a mild detergent, water and a soft cloth or sponge. The gasket should be clean and smooth.

9.1.2 Weekly

1. **ONCE PER WEEK**, clean the air jet. To ensure that the temperature inside the chamber rises properly it is necessary to keep the air jet clean. A dirty air jet will prevent indicator strips from changing color and cause spore tests to fail. See sec. 9.4.
2. Clean the water sensor in the rear of the chamber with a damp cloth or sponge. Cleaning the dirt off the sides of the sensor is more important than the tip (see sec 9.10).
3. Once per week clean and descale the chamber, copper tubes and the reservoir using Chamber Brite (see sec. 9.9).
4. Take out the tray holder and trays. Clean the tray holder and trays with detergent or a non-abrasive stainless steel cleaner and water, using a cloth or sponge. Rinse the tray holder and trays immediately with water to avoid staining the metal.



Caution

Do not use steel wool, steel brush or bleach as this can damage the chamber and trays!

5. Put a few drops of oil on the 2 door pins and door tightening bolt.
6. Clean the outer parts of the autoclave with a soft cloth

9.1.3 Periodically

1. Once every month clean and check the safety valve.
2. On EA models replace the air filter, every 6 months, or as needed (see sec. 9.2).
3. Replace the door gasket every 12 months, or as needed (see sec. 9.5).
4. Once every six months clean the fan grid with compressed air from the inside outward.
5. Clean strainer once a month as per sec. 9.8. Cleaning frequency may be reduced according to previous maintenance.
6. Once a year inspect the locking device for excessive wear.

9.2 Replacing the Air Filter (models EA)

To facilitate drying the instruments with the door of the chamber closed, models EA are equipped with an air compressor and HEPA filter (0.2 μ m). During the drying stage the compressor draws air through the HEPA filter and forces the circulation of that air through the heated chamber to remove moisture from the wrapped instruments. The filtration of the air is performed by the bacteriological filter and depending on the usage of the autoclave and the surrounding environment that will determine the frequency of replacement.

The filter is mounted in an opening on the right sidewall of the autoclave enclosure, this is to allow easy access for replacing it. (see picture below)

To replace the filter proceed as follows:

1. Remove the securing screws and then the filter cover by turning the cover counter-clockwise until the handle is at a vertical position.
2. Pull out the cover with the filter attached.
3. Disconnect the flexible tube from the filter
4. Replace the filter with a new one connecting it to the flexible tubing.
5. Reassemble the cover and lock it into position by turning it a 1/4 turn.
6. Fasten the securing screws.

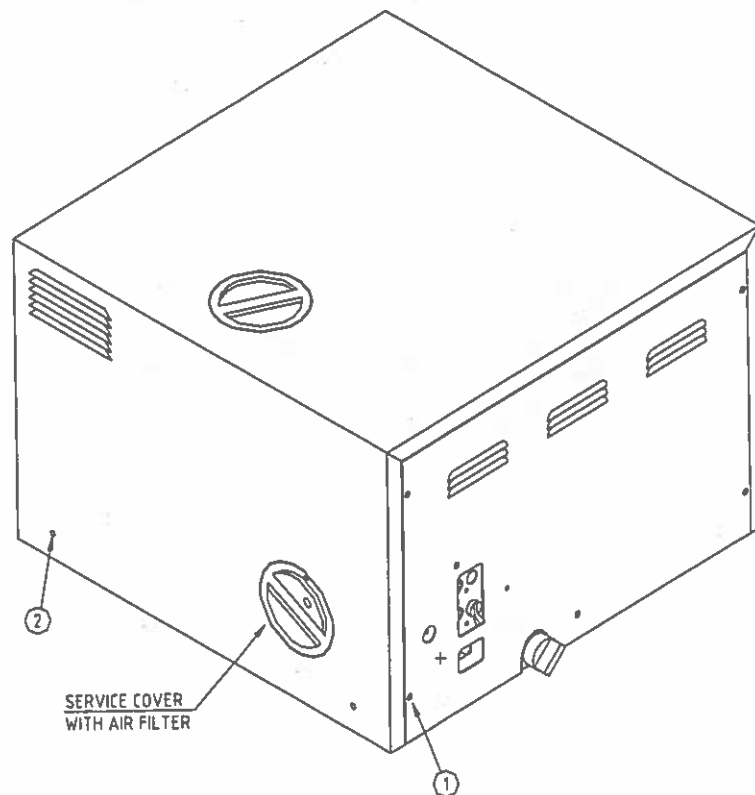

9.3 *Draining the Reservoir*



Caution

Before starting, ensure that the electric cord is disconnected and there is no pressure in the autoclave.

The drain valve is located on the front left side of the autoclave after the door is opened. The function of the drain valve is to drain the water reservoir.

1. Connect the silicone hose, supplied with the autoclave, to drain into a bucket.
2. Turn drain valve counter clockwise to the open position.
3. Fully drain the reservoir.
4. With a quart of tap water flush out the reservoir.
5. Turn drain valve clockwise to the close position.
6. Connect the electric cord to power source.
7. Fill the reservoir with mineral-free water to just below the safety valve (see sec 6.5)
8. Turn on the main power switch.
9. The autoclave is now ready for use.

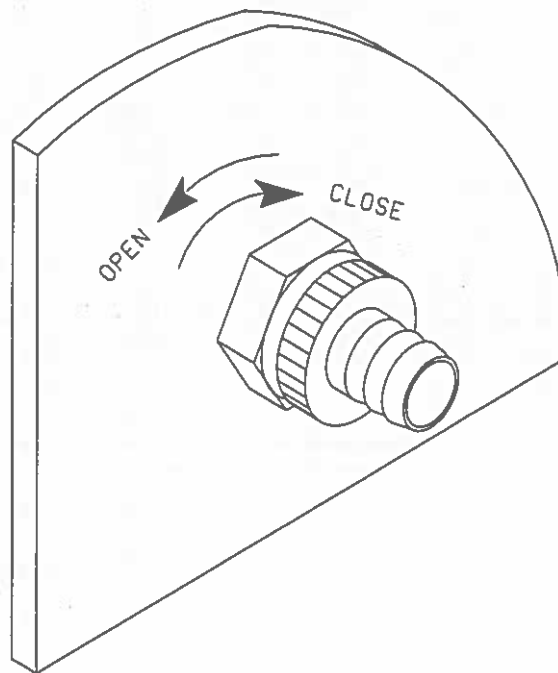

9.4 Cleaning Air Jet
(Located in the water reservoir.)



A dirty air jet is the number one cause of failed spore tests

The elimination of air from the sterilization chamber during heat up is **critical** to the proper operation of the autoclave. Failure of the air removal system will be responsible for incomplete sterilization, indicator strips that do not turn, failed spore tests and aborted sterilization cycles. A clogged air jet will result in receiving the error message "Low Heat".

The air jet consists of a small orifice with a clean out wire inserted in it (wire is permanently installed and will not come out). It is required that the air jet be cleaned once per week or more often if necessary, to remove any accumulated dirt and debris.

It is preferred to clean the air jet when the unit is running a cycle and under pressure. This is so that any loosened debris will be blown away, however, it can be done while the unit is idle.

1. Remove the water reservoir cover.
2. Clean the hole of the jet by manipulating the air trap wire back and forth 10 times

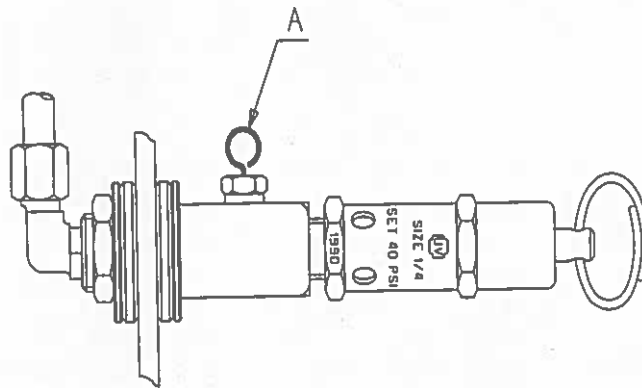

It is important to clean the hole of the air trap, as described at point 2 before starting operation of the autoclave, for the first time.

9.5 Replacing the Door Gasket

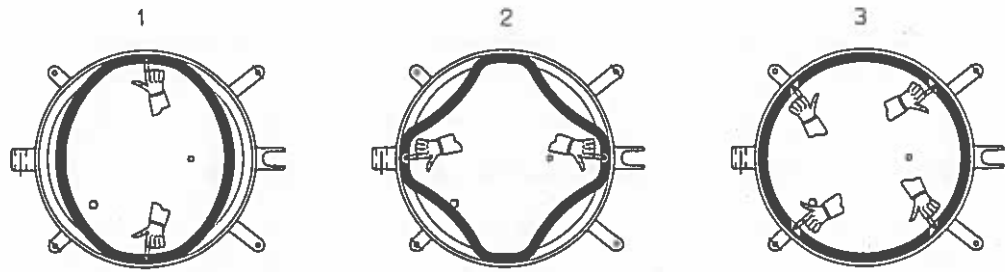

Pull off the gasket from the door groove. Install the new gasket as described in drawings 1, 2 and 3 above.

Caution!



This gasket is designed with a trapezoidal cross section. The gasket should be placed with the widest side towards the door.

9.6 *Checking the Safety Valve* (Located in the water reservoir)

In order to prevent the safety valve from becoming blocked, it is necessary to allow the steam pressure to escape through the valve. This procedure should be done every month as follows:

1. Operate the sterilization cycle according to the manual.
2. Allow a pressure of approximately 30 psi (260 kpa) to build up in the chamber.
3. Turn the unit off
4. Remove water reservoir cover



Caution!

This next step will expose you to HOT STEAM



Caution!

To avoid being burned, by hot steam, do not place your face over the safety valve.

5. Pull the ring of the safety valve using a tool, i.e. screwdriver, hook etc and open the safety valve for 2 seconds then release. Be careful not to burn your hands.
6. Turn the unit back on and press the STOP key to abort and vent the cycle.
7. Wait until pressure decreases to zero, only then can the door be opened.

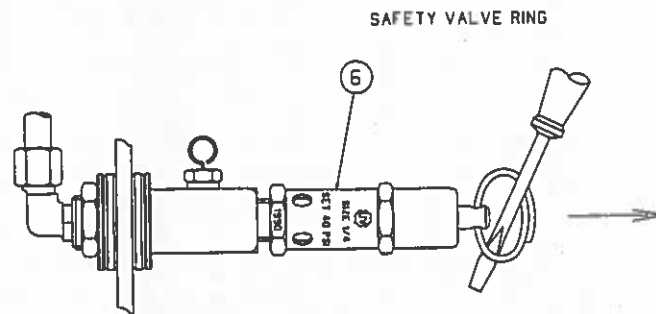

9.7 Replacing the Fuse



Caution

Make sure that the electrical power cord is disconnected!

Use a screwdriver to unlock the fuse holder cover by turning it counter clockwise ¼ turn, and pull it out.

Insert a new fuse into the holder and turn the cover clockwise until locked.



Make sure that the correct fuse is installed

1. Water Pump Fuse: 1.25 amps
2. Air Pump Fuse: 2.0 amps for 120V
1.25 amps for 230V

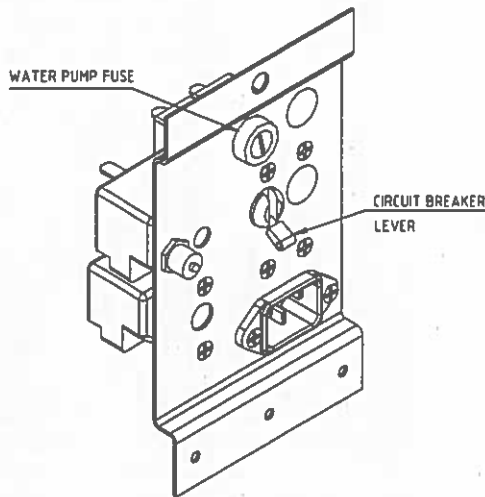

**For autoclaves
Models E, EK
(without an air pump)**

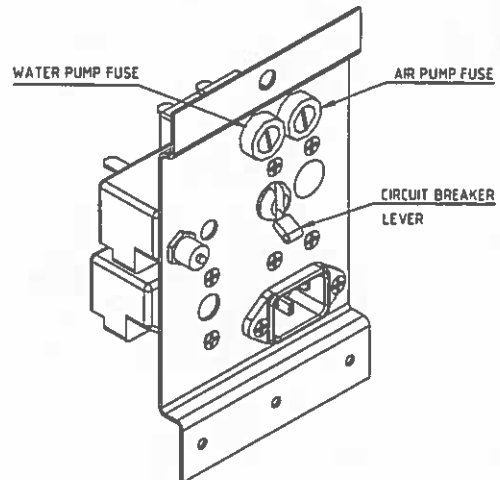

**For autoclaves
Models EA
(with an air pump)**

9.8 *Cleaning water outlet strainer*



Caution!

Before proceeding, Make sure that the electric cord is disconnected and there is no pressure or water in the chamber.

Warnings



1. *The strainer's cover is HOT*

Do not touch the strainer's cap, mounted on the exhaust line, during and shortly after operation. Touching the hot strainer's cap may cause severe injuries.

2. *If maintenance operation is performed while strainer cap is hot, use heat resistant gloves to avoid injuries.*

1. Open the strainer cap.
2. Remove the strainer element.
3. Rinse the strainer with water, using a brush if necessary.
4. Reinstall the strainer element.
5. Close the strainer cap

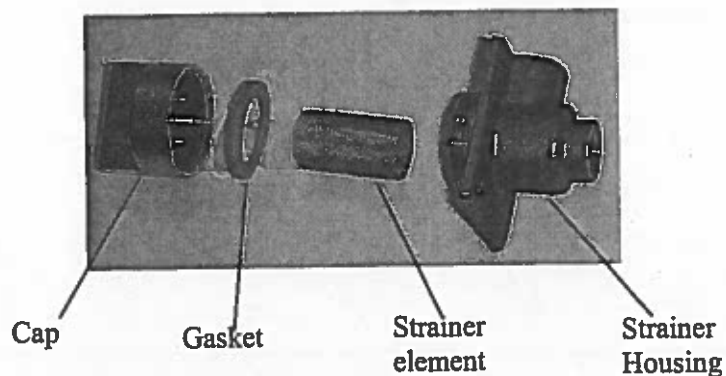
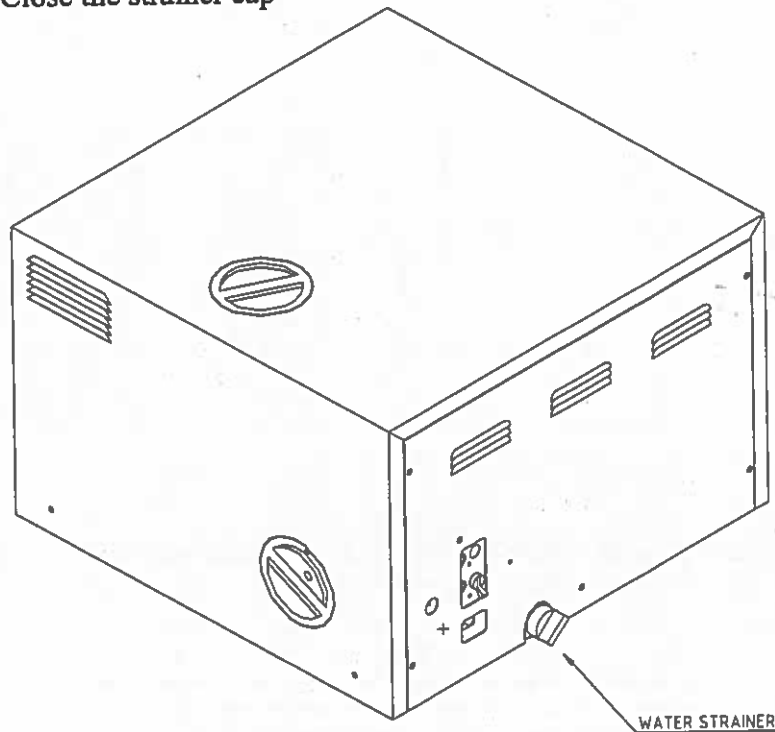

9.9 *Cleaning Table Top Autoclaves with Chamber Brite™*

CHAMBER BRITE™ is a cleaning and descaling agent designed specifically for the cleaning and removal of water deposits, oxides and other sediments that are found in steam sterilizers. The material is a combination of acidic salts and additional cleaning materials. Chamber Brite™ autoclave cleaner has been formulated specifically to be a fast, powerful and easy to use cleaner for steam sterilizers.

If the autoclave is not cleaned regularly dirt and debris will build up and clog the tubing and solenoid valves. This dirt can also be transmitted to the instruments during sterilization. In addition a layer of dirt on the stainless steel chamber traps moisture against the metal and will lead to the chamber becoming porous and failing.

It is recommended that your autoclave be cleaned with CHAMBER BRITE™ once per week



Caution!

NEVER use bleach, steel wool, a steel brush or anything abrasive to scrub or clean the Chamber

Cleaning Procedure

1. Important – all steps in this procedure must be completed without interruption.
2. When the autoclave chamber is cold, remove instruments and trays from the autoclave.
3. Open the door and spread the contents of a packet in a straight even line along the bottom of the chamber, from back to front.
4. Select and start program No. 1. (**without dry**) When the cycle is finished it will automatically exhaust
5. At the end of the exhaust cycle drain the water from the reservoir.
6. Fill the water reservoir with distilled water.
7. Repeat a sterilization cycle without Chamber Brite™ powder, to remove any excessive dirt in the pipes. Select and start program No. 1. (**without dry**) When the cycle is finished it will automatically exhaust
8. At the end of the exhaust cycle drain the water from the reservoir.
9. Turn the autoclave off and allow chamber to cool.

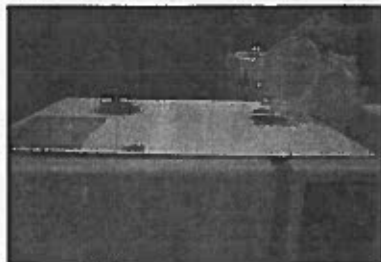
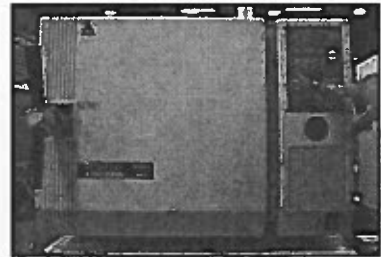

10. Remove the tray holder; rinse and wipe the interior of the chamber with a damp cloth.
11. Fill the reservoir with distilled water or mineral free water only.
12. Press the manual water fill button and allow a small amount of water (2-4 ounces) to fill chamber and flush out the fill tube. Remove water from chamber.
13. The instrument is ready to use.



IMPORTANT:

DO NOT sterilize instruments during the cleaning process!!!

CAUTION:

Keep out of reach of children. Contains mildly acidic ingredients. Avoid contact with the skin, eyes or clothing. Wash hands well after touching the powder, in the case of eye contact flush with continuous running water for at least 15 minutes. If irritation persists get medical attention. If accidentally swallowed, do not induce vomiting, drink large amounts of water and obtain medical attention. MSDS available upon request.



For models 1730, 2340, 2540 use one packet of CHAMBER BRITE™.

For models 3545, 3850, 3870 use two packets of CHAMBER BRITE™.

Clean every 20 cycles or as needed.

9.10 *Water Sensor Cleaning*

It is required that the water sensor be cleaned at least once per week. Cleaning the sensor will ensure that the water level in the chamber is properly reported to the microprocessor all during the cycle.

The water sensor is located in the rear of the chamber. It is easily cleaned using a damp cloth or sponge, you may use a mild soapy solution if you like. It is important to wipe the sides of the sensor as well as the tip, to remove any dirt or debris that may have built up.

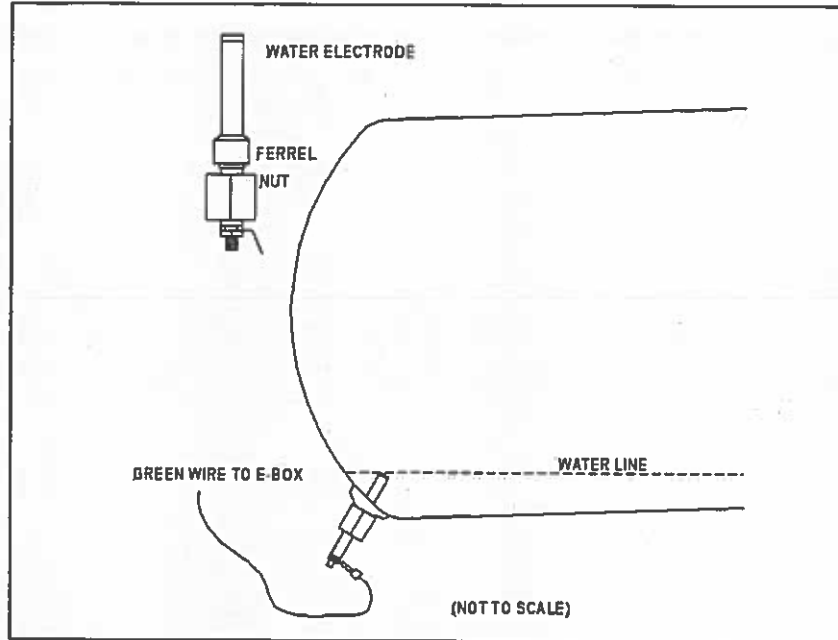

10 TROUBLESHOOTING FOR THE OPERATOR

This troubleshooting chart enables the user to solve minor malfunctions, prior to requesting service. Only technical personnel having proper qualifications and holding technical documentation (including a technician manual) and adequate information are authorized to service the apparatus.

<i>Problem</i>	<i>Solution</i>
1. The machine is not responding	1.1 Make sure the main switch is in the 'On' position. (see front view drawing at the front of this manual) 1.2 Make sure the power cord is properly connected to the machine and the mains. (see rear view drawing at the front of this manual) 1.3 Check the reset button on the cut-out thermostat. (see rear view drawing at the front of this manual) 1.4 Make sure the circuit breaker has not tripped. Lift the circuit breaker lever.
2. 'Low Heat' is displayed	2.1 Check the air trap (inside the water reservoir). (see sec. 9.4 Air Jet Cleaning Procedure) 2.2 Make sure the machine has the proper amount of sterilization load.
3. 'Low Water' is displayed	3.1 Clean the water level electrode inside the vessel. (see sec 9.10) 3.2 Check that the door is fully closed, the door gasket is seated and there is no steam leakage. Replace the door gasket if necessary. (see sec. 9.5 Replacing the Door Gasket) 3.3 Check the leveling of the machine. (see sec. 6, Installation).
4. 'Low Pres' is displayed	4.1 Clean the water level electrode inside the vessel. (see sec 9.10) 4.2 Check that the door is fully closed, the door gasket is seated and there is no steam leakage. Replace the door gasket if necessary. (see sec. 9.5 Replacing the Door Gasket) 4.3 Check the leveling of the machine. (see sec. 6, Installation).

<i>Problem</i>	<i>Solution</i>
5. 'Low Temp' is displayed	5.1 See Low Water problem above 5.2 The sterilization time has been set for too long of a period, allowing the chamber to run dry.
6. 'High Temp' is displayed	6.1 If this message is displayed during heat up it indicates a bad temperature sensor 6.2 Heating elements are remaining on instead of cycling on and off. In both cases call for a technician.
7. 'High Pres' is displayed	7.1 Air jet is clogged. Clean air jet according to sec. 9.3. 7.2 Heating elements are remaining on instead of cycling on and off. Call for a technician. 7.3 temperature sensor (PT100) is faulty or dirty. Call a technician.
8. The printer prints, but nothing is printed on the paper.	8.1 Make sure the paper is mounted in the right way. Only one side of the paper is printable. (see sec. 5.2, Printer handling)
9. The printer does not print.	9.1 Make sure the paper is inserted in the printer. (see sec. 5.2, Printer handling) 9.2 Switch off the machine and switch it back on while pressing the feed button on the printer. If the printer prints a test printout, the printer is O.K. and there is a problem with the electronics. Contact your dealer to solve the problem. If the printer does not print the test printout, there is a problem with the printer. Contact your dealer to solve the problem.
10. When the machine is switched on, the printer gives paper feeds all the time.	10.1 Make sure the 'feed button' on the printer is not stuck.

<i>Problem</i>	<i>Solution</i>
11. The machine is leaking at the door	11.1 Make sure the door is tightened enough and the door gasket is sealing the Chamber. Replace the door gasket. (see sec. 9.5 Replacing the Door Gasket)
12. When running a cycle, the exhaust stage takes a very long time.	12.1 If you are running a 'liquids' program this is normal. The slow exhaust will take from between 15 and 20 minutes. (see, PROGRAM 3 sec 4.3)
13. Water does not exit chamber due to clogged outlet strainer.	13.1 Clean strainer according to instructions. (see sec 9.8)
14. The drain is clogged	14.1 Open drain by turning counterclockwise. Place a heavy object over the reservoir cover. Blow compressed air into the drain, this should force any debris back into the reservoir. Clean out the reservoir. 14.2 Disassemble the drain valve by turning counterclockwise past the stop point. Remove the valve and clean, blow out the line as needed. Reassemble the valve by turning clockwise, make sure to press the large "O" ring into the groove on the autoclave.
15. Spore test are failing or indicator strips are not turning	15.1 Clean the air jet as per sec 9.4. 15.2 Make sure the sterilization time and temperature are set correctly, if in doubt use the default settings. 15.3 Make sure the autoclave is not to heavily loaded. See sec 7.
16. Wrapped items come out wet	16.1 Drying cycle may be too short. (see sec 4) 16.2 Autoclave may be overloaded. (see sec 7) 16.3 The chamber strainer may be clogged (see sec 9.8). 16.4 The HEPA filter may be clogged (see sec 9.2)
17. Wraps come out burned	17.1 Water sensor may be dirty (see sec 9.10) 17.2 Wall outlet voltage may be to high 17.3 Items may be touching the walls or bottom of the chamber. Load autoclave according to instructions in sec 7 (Preparation Before Sterilization).

<i>Problem</i>	<i>Solution</i>
18. Instruments are rusting	<p>18.1 First to determine true rust, use a pencil eraser to remove the brown spot. If there is no pitting then the instrument is just dirty (see sec 7 Preparation before sterilizing and sec 9.9 Cleaning the autoclave). If there is pitting beneath the brown spot then the rusting may be caused by minerals in the water used for rinsing (see sec 7 Preparation before sterilizing).</p> <p>18.2 Use only distilled water for sterilizing</p> <p>18.3 Make sure dissimilar metals (carbon steel, stainless steel, etc) have not come into contact with each other.</p>
19. Keyboard does not respond	19.1 Press the STOP key for 2 seconds to abort any program that may still be running
20. Autoclave takes too long to heat up	<p>20.1 Clean the air jet (see sec 9.4).</p> <p>20.2 Check for proper voltage at the wall outlet</p>
21. Loud noise coming from reservoir	21.1 Sterilization temperature set to high. Maximum setting 134°C (274°F)
22. Drying takes too long	<p>22.1 The autoclave may be overloaded (see sec 7 Preparation for Sterilization)</p> <p>22.2 Replace the HEPA filter (see sec 9.2)</p>
23. Chamber not filling	<p>23.1 check water level in reservoir.</p> <p>23.2 Check for an obstruction at the bottom of the reservoir blocking the pick up tube</p> <p>23.3 Clean the water sensor (see sec 9.10)</p> <p>23.4 Try filling the machine manually using the Manual Inlet key (see sec 3)</p>

<i>Problem</i>	<i>Solution</i>
24. Chamber very dirty	24.1 Use Chamber Brite™ to clean the autoclave, very dirty machines may require two cleanings. (see sec 9.9)
25. Trays and rack very dirty	25.1 Remove the trays and rack and clean as per instructions in sec 9.1.2
If the problem persists, contact your dealer or Tuttnauer USA for further assistance.	

